

HEWLETT-PACKARD

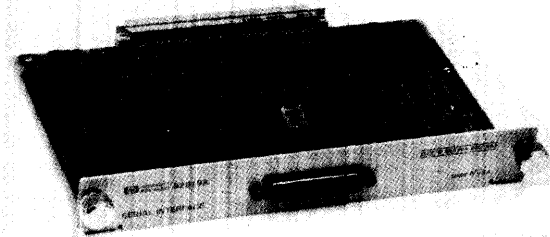

**Serial Interface
Component Level Service Manual**



Integral Personal Computer

Serial Interface

Component Level Service Manual

©Hewlett-Packard Company 1984

Reorder Number
82919-90009

Printed in U.S.A.
2/85

Printing History

Edition 1

February 1985

Mfg. No. 82919-90010

Contents

Chapter		Page
1	Product Information	
1.1	Introduction	1-1
1.2	Description	1-1
1.3	Accessories	1-1
1.4	Specifications/Technical Data	1-2
1.5	Serial Number Information	1-2
2	Site Preparation and Requirements	
3	Installation and Configuration	
4	Preventive Maintenance	
5	Functional Description	
5.1	Introduction	5-1
5.2	Bus Interface Circuit	5-2
5.3	ID/Status Register Circuit	5-3
5.4	Timing and Control Circuit	5-3
5.5	Dual-Channel UART	5-4
5.5.1	Data Bus Buffer	5-4
5.5.2	Timing	5-5
5.5.3	RS-232-C Data Channels	5-5
	Transmitter Operation	5-5
	Receiver Operation	5-5
5.5.4	Input Signal Port	5-5
5.5.5	Output Signal Port	5-6
5.5.6	Operation Control	5-6
5.5.7	Interrupt Control	5-6
5.6	RS-232-C Interface Circuit	5-6
6	Removal and Replacement	
6.1	Introduction	6-1
6.2	Removal and Installation Procedures	6-2
	Installation Procedure	6-2
	Removal Procedure	6-3
6.3	Disassembling the Interface	6-3
6.4	Reassembling the Interface	6-3

Chapter	Page
7	Adjustments
8	Troubleshooting and Diagnostics
8.1	Introduction 8-1
8.2	Installation Guidelines 8-2
8.3	PCA Component Level Repair 8-3
8.3.1	Troubleshooting Pointers 8-3
8.3.2	Initial Preparation Procedure 8-3
8.3.3	Diagnostic Testing Procedure 8-4
8.3.4	Verification Procedure 8-9
8.3.5	Description of Tests 8-11
8.3.6	Error Types, Causes, and Repair Procedures 8-13
	Power-Up Problems 8-13
	Type 1 Error—DTACK not received 8-14
	Type 2 Error—UART data error 8-16
	Type 3 Error—ID/Status Register error 8-19
	Type 4 Error—Interrupt error 8-20
	Type 5 Error—RESET error 8-22
	Type 6 Error—UART transmit/receive error (A originate) 8-23
	Type 7 Error—UART transmit/receive error (B originate) 8-24
	Type 8 Error—UART port error 8-25
	Type 9 Error—UART interrupt error 8-26
	Type 10 Error—Replace U5 8-26
9	Replaceable Parts
9.1	Introduction 9-1
9.2	Ordering Information 9-1
10	Reference
	Related Equipment Manuals 10-1
	Applicable Standards Specifications 10-1
11	Product History 11-1
12	Diagrams 12-1

Illustrations

Figure	Title	Page
1-1	Serial Bar Code Format	1-2
5-1	Serial Interface Block Diagram	5-1
5-2	UART Block Diagram	5-4
6-1	I/O Port Cover Removal	6-2
6-2	Module Insertion into the HP Integral PC	6-2
8-1	Main Menu	8-4
8-2	Serial Menus	8-5
8-3	General Troubleshooting Flowchart	8-10
9-1	Serial Interface Exploded View	9-2
12-1	RS-232-C Connector Pin Numbering	12-1
12-2	HP 82919-60903 Serial Test Connector	12-1
12-3	PCA Component Location Diagram	12-2
12-4.1	General Waveform Schematic	12-3
12-4.2	Data Test Waveform Schematic	12-4
12-4.3.1	ID/Status Register Test Waveform Schematic	12-5
12-4.3.2	ID/Status Register Test Waveform Schematic	12-6
12-4.4	Interrupt Test Waveform Schematic	12-7
12-4.5	UART Interrupt Test Waveform Schematic	12-8
12-4.6	UART Port Test Waveform Schematic	12-9
12-4.7	UART Transmit Test Waveform Schematic	12-10
12-5	Serial I/O Interface Schematic Diagram	12-11

Tables

Table	Title	Page
1-1	RS-232-C Cables	1-2
1-2	Specifications	1-3
5-1	Signal Names and Descriptions	5-2
5-2	RS-232-C Connector Pin Assignments	5-7
6-1	Tools Required for Interface Disassembly	6-1
8-1	Tools Required for Servicing	8-2
8-2	Error Types and Submessages	8-6
8-3	Error Types/Troubleshooting Procedures Index	8-8
8-4	Diagnostic Test Select Keys	8-11
9-1	Replaceable Parts for the HP 82919A Serial Interface	9-2
9-2	Replaceable Parts for the Serial Interface PCA	9-3

Preface

This manual contains information to help you troubleshoot and repair the HP 82919A Serial Interface, which is used with the HP Integral Personal Computer.

The information in this manual covers repair of a serial interface at the assembly level and at the component level.

The manual is divided into 12 chapters:

1. Product Information—A description of the serial interface.
2. Site Preparation and Requirements—Defines required operating and site preparation procedures.
3. Installation and Configuration—Provides specification/functional verification procedures.
4. Preventive Maintenance—Process used to keep the product or system in an operational state: user and service procedures.
5. Functional Description—Functional level description of operation.
6. Removal and Replacement—Instructions and procedures necessary to remove and replace entities of the product.
7. Adjustments—Procedures necessary to make the product or item conform to published specifications.
8. Troubleshooting and Diagnostics—Definition of process to identify working and non-working parts, and recommendations for correction.
9. Replaceable Parts—Complete listing and identification of all orderable parts.
10. Reference—Miscellaneous technical data referenced in the body of the document text.
11. Product History—Changes required to adapt the manual to an older product.
12. Diagrams—Schematics and other graphics.

Chapter 1

Product Information

1.1 Introduction

This chapter contains a brief description of the HP 82919A Serial Interface, accessory cables, specifications and technical data, and warranty status (date of manufacture).

1.2 Description

The HP 82919A Serial Interface provides serial data communications capability for the HP Integral PC. The interface plugs into a computer I/O port and connects to **serial** devices via its (male) 25-pin sub-miniature D connector and RS-232-C cable. The connector meets ISO International Standard 2110-1980.

The interface can drive one or two **asynchronous** data channels. Each channel is independent of the other channel, and can communicate in full-duplex, half-duplex, or simplex transmission mode. Data can be transferred at independently selectable baud rates of from 50 to 38,400.

1.3 Accessories

The serial interface is connected to a peripheral device by one of four cables: refer to table 1-1. Each cable configures its RS-232-C **output** connector for single (**A**) channel communication either as data terminal equipment (DTE) or as data communication equipment (DCE).

If you want to implement the secondary (**B**) channel, you will need to construct a special cable—refer to figure 12-1 for the pin configuration of the RS-232-C connector on the back panel of the interface.

Table 1-1. RS-232-C Cables*

Cable Application	Part Number
Modem, DTE (female/male output)	HP 82974A
Instrumentation, DCE (female/female output)	HP 82974B
Printer, DCE (female/female output)	HP 82974C
Printer, DCE (female/male output)	HP 82974D

* These (4) cables do NOT implement the SECONDARY data channel:
You will need to construct a special cable if you want to use the secondary (**B**) channel—refer to figure 12-1 for the pin configuration of the RS-232-C connector on the back panel of the interface.

1.4 Specifications/Technical Data

The serial interface conforms to EIA (Electronic Industries Association) Standard RS-232-C and CCITT (Comite Consultatif Internationale de Telegraphie et Telephonie) Recommendations V.24 and V.28.

Specifications of the serial interface are listed in table 1-2.

1.5 Serial Number Information

Date of manufacture of the interface is used to determine warranty status. The bar code label on the printed-circuit board contains a 9-digit date code. Its format is described as follows:

Example



Key:

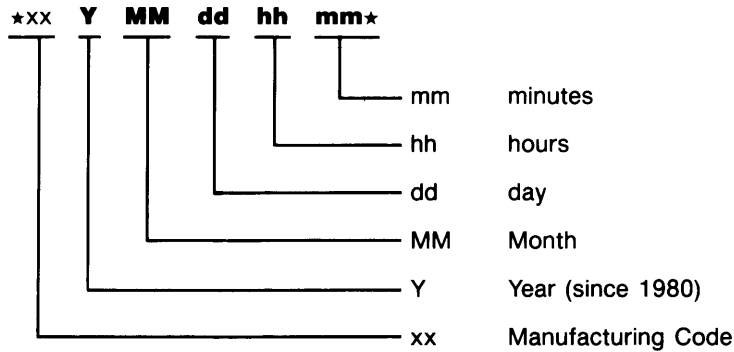

Figure 1-1. Serial Bar Code Format

Table 1-2. Specifications

Physical Properties

- Dimensions: 19.10 cm × 13.50 cm × 2.70 cm (7.52" × 5.31" × 1.06").
- Weight: 218 gm (7.7 oz).
- DC Voltages: +12V, +5V, -12V provided by the HP Integral PC.

Power Consumption

- Theoretical Worst Case: +5V: 1.83W; +12V: 1.00W; -12V: 1.00W;
Total: 3.83W.
- Theoretical Typical: +5V: 0.99W; +12V: 0.46W; -12V: 0.43W;
Total: 1.88W.
- Measured: +5V: 0.91W; +12V: 0.50W; -12V: 0.69W;
Total: 2.10W.

Compatibility

- Plugs into the HP Integral PC I/O port.
- Uses standard HP Integral PC I/O driver.
- Fully compatible with EIA Standard **RS-232-C** and CCITT Recommendations **V.24** and **V.28**.
- Data transmission mode: Asynchronous—full-duplex, half-duplex, or simplex.
- Fixed baud rates of 50, 75, 110, 134.5, 150, 200, 300, 600, 1050, 1200, 1800, 2000, 2400, 4800, 7200, 9600, 19200, and 38400 are independently selectable on both data channels in transmit and receive modes. Note that the interface requires highest interrupt priority level for reliable operation at 19200 baud. Operation at 38400 baud is not guaranteed. Your computer's operating system may limit the baud rate to 9600.

RS-232-C Cable

- Configuration: DTE or DCE. (Refer to figure 12-1 for RS-232-C connector pin numbering).
- Length: 2m (6.6 ft).

Environmental Limits

- Operating Temperature: 0 to 40°C (32 to 104°F).
- Storage Temperature: -40 to +75°C (-40 to +167°F).
- Operating Humidity: 5 to 95 percent relative humidity at 40°C (104°F).

Chapter 2

Site Preparation and Requirements

No site preparation procedures are required.

Chapter 3

Installation and Configuration

There are no installation or configuration requirements.

Chapter 4

Preventive Maintenance

No preventive maintenance procedures are required.

Chapter 5

Functional Description

5.1 Introduction

The HP 82919A Serial Interface consists of these 5 major circuits:

1. Bus interface.
2. ID/status register.
3. Timing and control.
4. Dual-channel UART (universal asynchronous receiver/transmitter).
5. RS-232-C interface.

These circuits are connected according to the block diagram in figure 5-1 and are described below. Table 5-1 lists the names and descriptions of I/O bus signals and internal signals used by the interface.

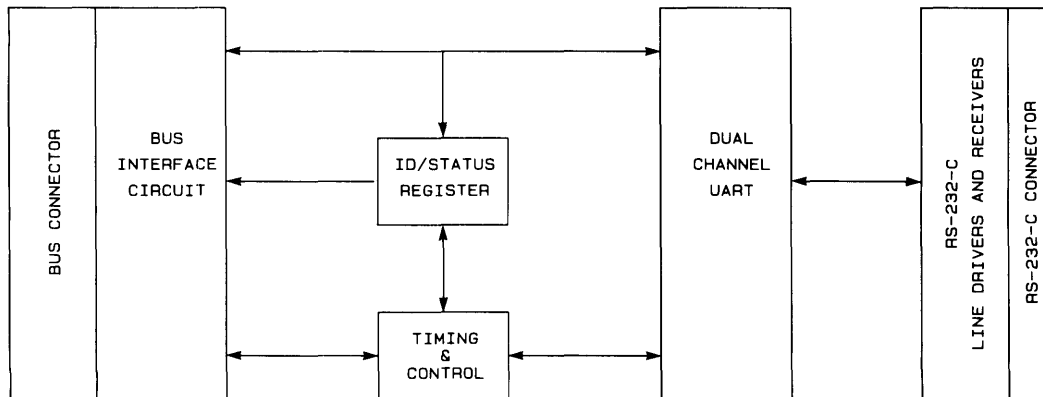

Figure 5-1. Serial Interface Block Diagram

Table 5-1. Signal Names and Descriptions

Name	Description	Direction
BA1-BA5	Bus address signals	Computer → Interface
BD0-BD7	Bus data signals	Computer ↔ Interface
BR/NW	Bus Read/Write	Computer → Interface
NBDTACK	Data Transmit Acknowledge	Computer ← Interface
NBIR0-NBIR3	Interrupt Request Signals	Computer ← Interface
NPS	Port Select	Computer → Interface
NBRESET	Reset	Computer → Interface
+5V	+5V Supply	Computer → Interface
+12V	+12V Supply	Computer → Interface
-12V	-12V Supply	Computer → Interface
GND	Ground	—
CSN	Chip Select (UART)	(Internal)
$\overline{\text{FI}}$	Force Interrupt	(Internal)
$\overline{\text{URTINT}}$	UART Interrupt	(Internal)
ID/SCLCK	ID/Status Clock	(Internal)
$\overline{\text{ID/SEN}}$	ID/Status Enable	(Internal)
$\overline{\text{IE}}$	Interrupt Enable	(Internal)
INTLA, INTLB	Interrupt Level Signals	(Internal)
IP	Interrupt Pending	(Internal)

5.2 Bus Interface Circuit

The bus interface circuit consists of 96-pin female connector P1, transceiver U1, 2-to-4 decoder U6, and buffers U3, U4, and U9.

The 96-pin connector interfaces with the HP Integral PC I/O bus: it connects power, data, address, control, and interrupt lines between the interface and the computer. (Refer to the schematic diagram, figure 12-5 for connector pin assignments.)

The eight-channel transceiver buffers data being sent on lines BD7 thru BD0 between the interface and the HP Integral PC. Direction of data transfer is determined by input signal BR/NW from the computer. When the interface isn't being accessed (NPS **high**), the transceiver is in a tri-state condition.

Line **NBLD** from the HP Integral PC isn't used by the serial interface. However, the computer must set this line true (**low**) when transferring data to or from the serial interface, to ensure that valid data is transferred over the eight data lines (BD7 thru BD0). The **upper** eight data lines from the computer (BD15 thru BD8) are not used by the interface.

5.3 ID/Status Register Circuit

The ID/Status Register circuit consists of D-type flip-flop U2, and buffers U3 and U4. This circuit stores data which controls operation of interrupts, and sends data indicating interrupt condition and ID code (2) of the serial interface. The data is transmitted and received via the interface circuit and I/O bus. This circuit also generates interrupt signals on lines NBIR3 thru NBIR0.

During a data transfer from the HP Integral PC to the ID/status register, the timing and control circuit triggers flip-flop U2, which latches the four data lines BD7 thru BD4.

During a data transfer from the ID/status register to the computer, the timing and control circuit generates a gate signal which enables buffers U3 and U4. The output of U4 is fixed. The output of U3 is the same as the output of flip-flop U2, except that the U2 \overline{FI} output is NANDed with the \overline{URTINT} signal from the UART to indicate both normal interrupts (from the UART) and **forced** interrupts (from the ID/status register). The data is sent on data lines BD7 thru BD0.

The two interrupt level signals from flip-flop U2 (INTLA and INTLB) are used by decoder U6 also. A **low** \overline{IE} signal from U2 enables the decoder. Whenever the IP interrupt signal goes high, the decoder pulls one interrupt line (NBIR0 thru NBIR3) **low**, according to the state of the INTLA and INTLB signals. This sends an interrupt of the appropriate level to the HP Integral PC.

5.4 Timing and Control Circuit

The timing and control circuit consists of logic gates U7 and U8, and portions of U4 and U9. These components generate the signals required to control operation of the I/O bus transceiver, the ID/status register, and the UART.

During a data transfer between the HP Integral PC and the UART, the timing and control circuit requires input BA5 to be **high**. Input BR/NW is transferred to the UART to indicate the direction of transfer (BR/NW **low** indicates computer to UART transfer). The NPS input triggers the data transfer when it goes **low**. The circuit transfers the NBDTACK signal from the UART to the computer to indicate data available or data received at the UART.

During a data transfer between the HP Integral PC and the ID/status register, the timing and control circuit requires inputs NPS and BA5 to be **low**. Four-channel NAND gates U8A and U8B and inverter U7A use input BR/NW to control whether ID/status data is stored (BR/NW **low**) or sent (BR/NW **high**) by the ID/status register circuit. NAND gates U7C and U7D set the UART to receive data while the ID/status register is sending data (BR/NW high and BA5 **low**), so that the UART receives (but doesn't use) data that is being transferred to or from the ID/status register. The NBDTACK signal from the UART goes **low** when the transfer is complete.

5.5 Dual-Channel UART

The dual-channel UART is the workhorse of the serial interface. This IC provides two independent, full-duplex, asynchronous receiver/transmitter channels which are compatible with the EIA RS-232-C Standard. The UART transfers data to and from the HP Integral PC via the interface circuit. An external crystal circuit provides the 3.6864 MHz timing reference for the UART.

Data lines BD7 thru BD0 transfer both data and instructions to and from the UART. Thus, the UART operates according to instructions received from the computer via the interface circuit.

The functions within the UART can be separated into **seven** categories, which are shown in figure 5-2:

- Data bus buffer.
- Timing.
- RS-232-C data channels.
- Input signal port.
- Output signal port.
- Operation control.
- Interrupt control.

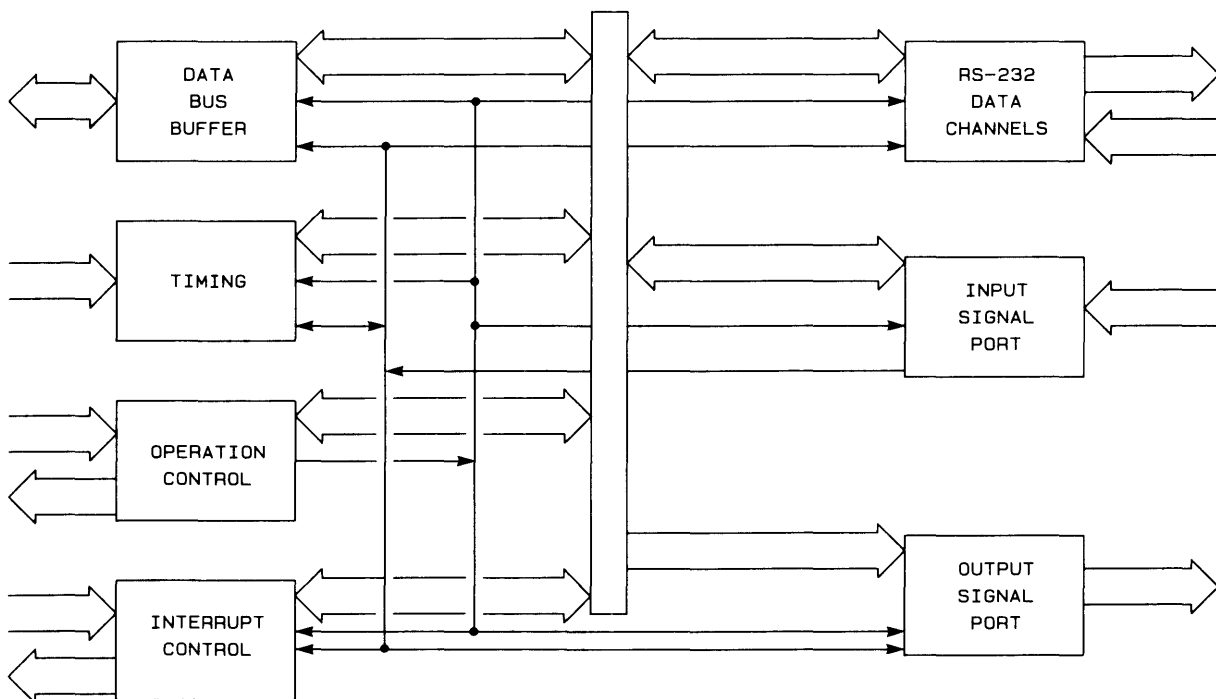

Figure 5-2. UART Block Diagram

5.5.1 Data Bus Buffer

The UART's data bus buffer provides the interface between the serial interface's data lines (BD7 thru BD0) and the internal UART data lines. The operation control function controls the transfer of data by the UART on the interface's data lines.

5.5.2 Timing

The UART's timing function consists of a 3.6864 MHz crystal-controlled oscillator, a baud rate generator circuit, a **programmable** counter/timer, and four clock selectors. The oscillator and baud rate generator circuit can generate 18 common baud rates, of which up to 4 can be selected for the RS-232-C data channel function. Alternatively, virtually any single baud rate can be generated (using the programmable counter/timer) and used by the RS-232-C data channel.

5.5.3 RS-232-C Data Channels

The UART provides two independent RS-232-C data channels, as allowed by the EIA RS-232-C Standard: channel A (lines TxDA and RxDA) is the **primary** channel, and channel B (lines TxDB and RxDB) is the secondary channel. The transmitter and receiver in each channel can operate at independent baud rates if provided by the timing function. The control function enables and disables the data channels and determines their operating characteristics (including baud rate, number of **stop** bits, and parity options).

Transmitter Operation. Each (UART) transmitter accepts **parallel** data from the bus interface circuit via the UART data bus buffer, converts the data to a **serial** bit stream, inserts appropriate start, stop, and optional parity bits, and transmits this (serial) data to the interface's RS-232-C circuit (least significant bit first). Each transmit channel can hold up to **two** bytes in its internal registers.

The transmitter begins sending data when the operation control function enables the transmitter, and directs data into the transmitter's internal register. If no data is available to send, the transmitter keeps the output signal **high**. If the transmitter is instructed by the HP Integral PC to send a **break** signal, it sets the output signal **low** until the computer cancels the break signal.

Receiver Operation. Each (UART) receiver accepts **serial** data from the RS-232-C interface circuit, checks for the start, stop, and optional parity bits, converts this data to **parallel** format, and sends the assembled data back to the RS-232-C bus interface circuit via the UART data bus buffer. Each receive channel can format and hold up to **four** bytes in its internal registers.

The receiver begins checking for incoming data when enabled by the operation control function. If the receiver detects a **high** → **low** transition on the input line, it begins sampling the input signal according to the selected bit rate. If it detects a valid **start** bit, it continues sampling for the total number of bits expected (data bits, optional parity bit; and at least 1 **stop** bit is required to avoid an error). Then it begins checking for another **start** bit. The received data byte is assembled in an internal register (using the **first** received data bit as the **least** significant bit).

Certain error conditions are detected by the receiver: **parity** error (improper bit pattern according to the selected parity option), **framing** error (**no stop bit** detected), and **overrun** error (bytes received faster than read from the receiver register—causing data loss). If the receiver detects an incoming **break** signal (continuous **low** input), it loads a **zero** byte into its register and awaits a valid **start** bit.

5.5.4 Input Signal Port

The UART's input signal port receives 6 input control signals from the serial peripheral device via 6 NAND receivers on the RS-232-C interface circuit. The HP Integral PC uses these signals (IP0 thru IP5) to control transfer of data to and from the serial peripheral device. **Low** signals from these six receivers are interpreted as logic 0s. Note that a **low** input signal is the active (**on**) state for the input signal port.

5.5.5 Output Signal Port

The UART's output signal port provides 8 output control signals. The serial interface uses only 5 of these signals as control signals to the serial peripheral device via 5 NAND drivers on the RS-232-C interface circuit. The HP Integral PC uses these signals (OP0 thru OP4 on the UART) to control transfer of data to and from the serial peripheral device. **Low** signals from the UART output signal port are interpreted as logic 0's. Note that a **low** output signal is the active (**on**) state for the output signal port.

5.5.6 Operation Control

The HP Integral PC controls operation of the UART by storing appropriate information in the UART's internal control registers. The computer receives operational information by fetching **status** information from the internal UART registers.

The operation control function provides the link between the HP Integral PC and the UART's operation. This function receives control signals from the computer and generates internal signals which control the operation of other internal UART functions.

The BR/NW input signal specifies whether the current operation is to store data from the HP Integral PC (BR/NW **low**) or to send data to the computer (BR/NW **high**). Four input address lines (A4 thru A1) specify the destination or source of data within the UART. This data may control the UART's operation, indicate its status, or represent information being transferred between the HP Integral PC and the RS-232-C peripheral device.

The NBDTACK output signal informs the computer that data has been received (during transfer **from** the computer), or that data is valid (during transfer **to** the computer).

The CSN (UART Chip Select) input signal must be **low** for the UART to be active. IF the (UART's) RESETN input signal goes **low** the UART clears certain internal registers that control operation, resetting the UART to its startup condition.

5.5.7 Interrupt Control

The interrupt control function maintains information concerning conditions which can cause interrupts and notifies the HP Integral PC whenever an interrupt event occurs.

The (UART) INTRN output signal is set **low** whenever an interrupt event occurs; the signal is set **high** when no interrupts are pending. This signal is sent to the HP Integral PC via the ID/status register circuit.

5.6 RS-232-C Interface Circuit

The RS-232-C interface circuit ensures that the serial interface's RS-232-C electrical characteristics conform to EIA Standard RS-232-C.

The +12V and -12V supply lines include diodes CR1 and CR2. These diodes prevent excessive power dissipation by the line drivers if the line driver outputs are shorted to $\pm 15V$ and there is a loss of the +12V and/or -12V supply.

The line drivers (U10 and U11) on all **output** lines invert signals sent by the UART. Each output line can withstand a short to any other line if the +12V and -12V supply voltages are at least +9V and -9V respectively. Capacitors on the output lines prevent the output signals from changing faster than ± 30 volts per microsecond.

The line receivers (U12 and U13) on all **input** lines invert the signals received from the serial peripheral device. Each receiver has an input impedance between 3000 and 7000 ohms (for input voltages between 3 and 25 volts and between -3 and -25 volts). The typical turn-off threshold is 0.8 volts; the typical turn **on** threshold is 1.9 volts. The maximum input voltage on any input line is ± 30 volts.

The serial interface is configured as a DTE (data terminal equipment). The RS-232-C connector on the serial interface is a male sub-miniature D connector, which is commonly used as a "standard" DTE connector. The pin assignments for this connector are listed in table 5-2. The HP 82974A Modem Cable extends a subset of these signals to its DTE connector for a single-channel application.

If the serial interface is to be used as a DCE (data communications equipment), the RS-232-C lines must be used in a complementary manner with a female connector—input lines and output lines must be interchanged. The HP 82974D Printer Cable provides such a connection for a **single**-channel application.

Table 5-2. RS-232-C Connector Pin Assignments*

Pin Number	Signal Name	Signal Direction
1	Power Ground	—
2	Transmitted Data	Interface → Peripheral
3	Received Data	Interface ← Peripheral
4	Request to Send	Interface → Peripheral
5	Clear to Send	Interface ← Peripheral
6	Data Set Ready	Interface ← Peripheral
7	Signal Ground	—
8	Received Line Signal Detector	Interface ← Peripheral
12	Secondary Received Line Signal Detector	Interface ← Peripheral
13	Secondary Clear to Send	Interface ← Peripheral
14	Secondary Transmitted Data	Interface → Peripheral
16	Secondary Received Data	Interface ← Peripheral
19	Secondary Request to Send	Interface → Peripheral
20	Data Terminal Ready	Interface → Peripheral
22	Ring Indicator	Interface ← Peripheral
23	Data Signal Rate Selector	Interface → Peripheral
24	Transmit Signal Element Timing	Interface → Peripheral

* Refer to figure 12-1 for RS-232-C connector pin numbering.

Chapter 6

Removal and Replacement

6.1 Introduction

This section describes the procedures used to disassemble and reassemble the HP 82919A Serial Interface. The section covers:

- Required Tools (refer to table 6-1).
- Interface Removal and Installation Procedure.
- Interface Disassembly and Reassembly Procedure.

CAUTION

Take adequate precautions for electrostatic protection—

WEAR A GROUNDED WRIST STRAP. WORK AT A BENCH WHICH IS ELECTROSTATICALLY PROTECTED !!

Otherwise, components may be damaged.

Table 6-1. Tools Required for Interface Disassembly

Quantity Required	HP Part Number	Description
1	—	Small crescent wrench
1	8710-1426	Torx® Kit
1	8710-1418	Torx driver, T-10 bit (included in Torx Kit).
1	—	Flat blade screwdriver

6.2 Removal and Installation Procedures

Use the following procedures to install and remove the serial interface module under test into the HP Integral PC at the service bench:

Installation Procedure

Step 1. Turn off power to the HP Integral PC and peripherals.

Step 2. Use the flat blade screwdriver to remove the covers from the I/O ports:

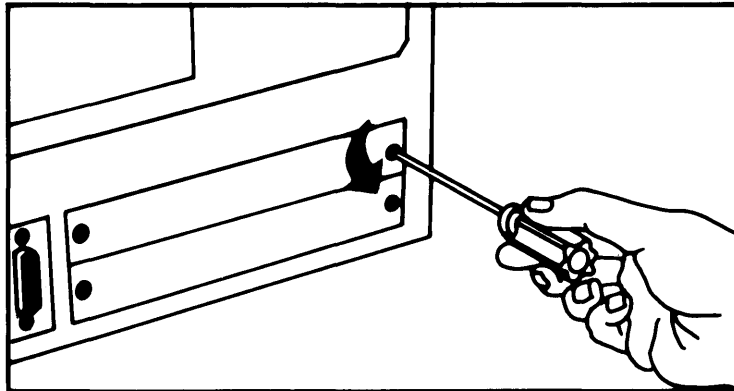

Figure 6-1. I/O Port Cover Removal

Step 3. Carefully insert the interface module into the card guides on both sides of the computer I/O port. Gently push the module in to engage the connector, then tighten the thumb screws:

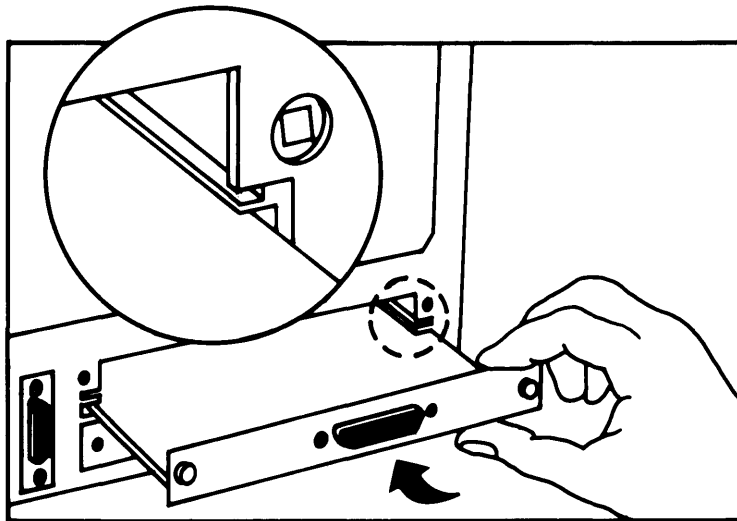

Figure 6-2. Module Insertion into the HP Integral PC

Step 4. Turn on power to HP Integral PC and peripherals.

Removal Procedure

1. Turn off power to the HP Integral PC and peripherals.
2. Remove any cable from the interface module.
3. Turn the thumb screws to disengage the module, then pull out and remove the module.

6.3 Disassembling the Interface

Refer to the Serial Interface Exploded View in figure 9-1

1. With the Torx driver, remove the four #T10 screws and attaching the bottom case to the PCA.
2. To separate the back panel assembly from the logic PCA, use the small crescent wrench to remove the two jackposts securing the RS-232-C connector. Note that two split lockwashers are used with the jackposts.
3. Separate the PCA from the back panel and the bottom case.

6.4 Reassembling the Interface

To reassemble the interface, reverse the above procedure.

Chapter 7

Adjustments

No adjustments are required on the Serial Interface Module.

Chapter 8

Troubleshooting and Diagnostics

8.1 Introduction

This section contains procedures to isolate the causes of problems in an HP 82919A Serial Interface. These procedures are also used to test the interface. Tools that facilitate service are listed in table 8-1.

CAUTION

Ensure that the setup for troubleshooting and repair has **ADEQUATE ELECTROSTATIC PROTECTION !!**

WARNING

To avoid personal injury and equipment damage, read and understand the safety precautions, and follow the installation guidelines below.

SAFETY PRECAUTIONS

Read and understand the following BEFORE connecting or disconnecting a serial interface or peripheral:

Manufacturers of peripheral devices do not all use the same grounding technique. **Earth and logic grounds are often at different voltage levels.** In some instances, this is a deliberate attempt to reduce ground return interference with digital signals.

When an HP 82919A Serial Interface is installed in an Integral PC, the **earth and logic grounds are connected.** Thus, if logic ground on a peripheral is never connected to earth ground, or if it is defective, it may have a voltage level considerably different from logic ground on the interface.

This voltage difference may be high enough to be hazardous unless peripherals are connected to the bus in an exacting manner.

If you don't know the grounding technique used on a peripheral, **check with the manufacturer of the device !!**

After verifying that suitable grounding techniques have been used on the peripheral, follow the installation guidelines given in paragraph 8.2.

8.2 Installation Guidelines

- Turn OFF the power to the computer and all peripherals BEFORE installing or removing the interface or any peripherals.
- Be sure that the computer is plugged into a grounded (three-wire) outlet.
- Always have the serial interface module installed in the computer whenever any peripherals are being connected or removed from the interface.
- Turn on the HP Integral PC and peripherals only after all connections are made.

Table 8-1. Tools Required for Servicing

Quantity Required	HP Part/Model Number	Description
1	HP 545A†	Logic Probe
1	HP 9807A	HP Integral PC
1	0960-0062	Continuity Tester
	or	or
1	HP 3469B†	Multimeter
1	N/A	Small Crescent Wrench
1	8710-1426	Torx® Kit (use T-10 bit)
1	82919-60903	Serial Test Connector
1	HP 82919A	Serial Interface (optional)
1	00095-60902	Port Extender
1	HP 1740A†	Oscilloscope
1	00095-60950	Component Level Diagnostic Disc
1	1400-0980*	40-pin IC clip
1	1400-0979*	20-pin IC clip
1	1400-0734*	8-14-16 pin IC clip

* recommended tool
† or equivalent

8.3 PCA Component Level Repair

8.3.1 Troubleshooting Pointers

- **Determine the customer's concern** if possible; ask if the problem is intermittent. This information may be helpful when evaluating test results: *IT DOES NOT REPLACE HP RECOMMENDED PROCEDURES.*
- **Observe symptoms:** try to duplicate condition(s) described by the customer. Note how observed/reported behavior differs from proper behavior; also note ALL functions which ARE working properly.
- **Identify problems:** correlate symptoms with distinct problems. Arrange problems in a logical sequence and solve them one at a time.
- **Consider possible causes for each problem:** keep them in mind as you troubleshoot.

8.3.2 Initial Preparation Procedure

1. Turn off the HP Integral PC.
2. Insert an 82919-60903 Serial Test Connector into the RS-232-C connector on the interface to be tested; then insert the interface into a 00095-60902 port extender. Make sure that switch, S1 is in the 'CLOSED' position. Insert the port extender into port 'B' of the Integral PC.

Note: It is important to use the correct computer port (B), otherwise the serial interface will not be recognized.

3. Check the 4 fuses on the port extender and replace any blown fuse(s) with a new fuse(s) of the same rating:

F1, F4	0.75A 250V
F2	0.375A 250V
F3	0.125A 250V

If a fuse is OK, its LED indicator will be on.

4. If a printout of test results is desired, *at least 10 pages of paper must be loaded in the printer:* if the printer runs out of paper during the automatic complete test, load more paper into the printer to continue the test.
5. If other than a U.S. mainframe, insert the appropriate localization disc.
6. Turn on the Integral PC: the main PAM screen should appear on the computer display. If the main PAM screen does not appear, go to the troubleshooting procedure for "Power-UP Problems" in section 8.3.6.

8.3.3 Diagnostic Testing Procedure. (refer to flowchart in figure 8-3)

1. Insert the 00095-60950 I/O Component-Level Diagnostic Disc into the HP Integral PC disc drive.
2. IO_COMP will appear after "Programs:" in the main window of the HP Integral PC display.*
3. Press the "Start" function key (f1).*
4. The following display will appear:

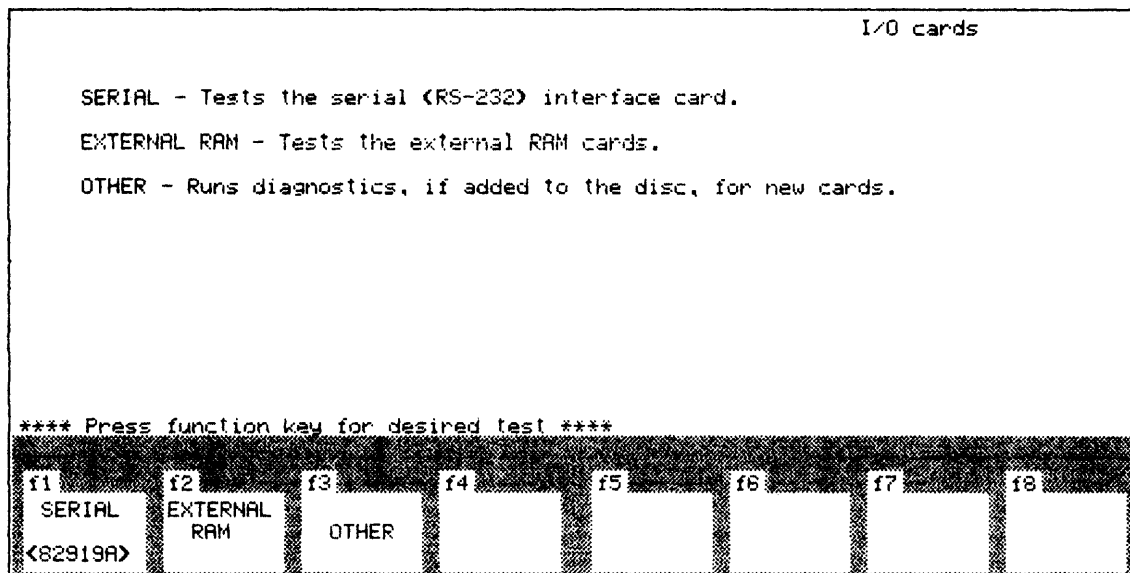
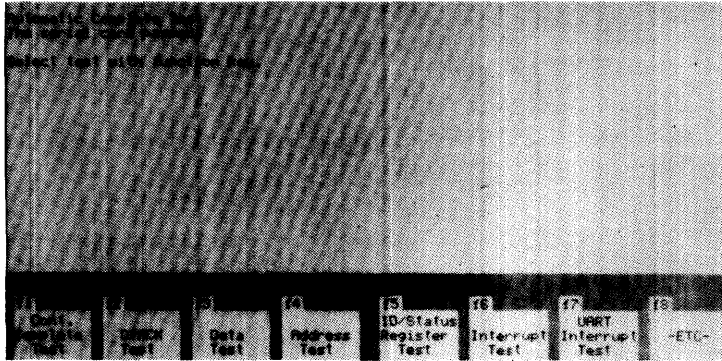

Figure 8-1. Main Menu

5. Press the SERIAL function key (f1) in the Main menu to run the Diagnostic program.
6. The auto serial test will begin.

* "Programs" and "Start" will appear in the selected language.

7. The 1st Serial Menu display will appear:



1st Serial Menu

2nd Serial Menu

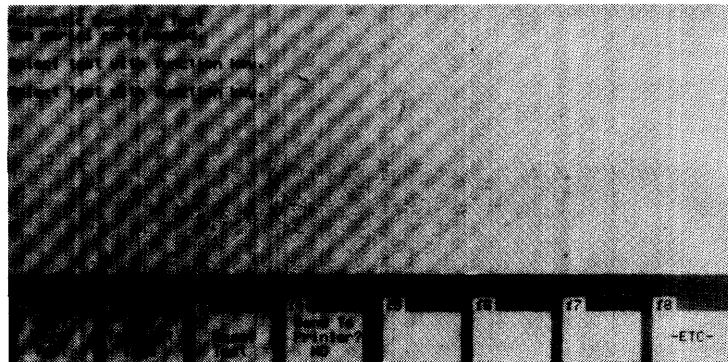

Figure 8-2. Serial Menus

8. The auto serial test can be aborted by **simultaneously** pressing **Shift** **CTRL** **Reset**. (This key combination is also used to abort the loop tests—refer to “Description of Tests”, in 8.3.5.) The following message will be displayed and printed:

```
**** Auto Test Aborted
**** Power Down and Rerun
```

If the auto SERIAL test is aborted, the only way to obtain a complete listing of error messages is to power down the computer and rerun the test, following the above procedures. Therefore,

THE AUTOMATIC SERIAL TEST SHOULD NOT BE ABORTED DURING NORMAL SERVICE/REPAIR PROCEDURES

because any errors on the HP 82919A Serial Interface board may not have been fully diagnosed, and an incorrect repair procedure might be used.

9. **Displaying and printing error messages during autotest:** All errors that are found during this test are displayed on the computer screen and printed. If the printer runs out of paper during the auto test, add paper to the printer to continue the test.
10. **Interpreting Diagnostic Error Messages:** There are 10 types of errors that can occur during the auto serial test. Each error type is prioritized from 1 to 10 (1 has highest priority). Table 8-2 shows all error types that can be detected by the diagnostic routine.

Note: The submessages displayed under major errors are useful for troubleshooting.

Table 8-2. Error Types and Submessages

Error Type	Message
1	** 1** DTACK not received Test aborted.
2	** 2** UART data error Data written: xxH.† Data read: xxH.†
3	** 3** ID/Status Register error ID was read as xH† instead of 2H. Attempted to write interrupt level of xH† into status register. Read an interrupt level of xH† in the status register. Interrupt enable bit stuck at 0 or Interrupt enable bit stuck at 1. Interrupt pending bit stuck at 0 or Interrupt pending bit stuck at 1.
4	** 4** Interrupt error Missing interrupt at level xH.† Configured interrupt level is xH.† Incorrect interrupt level at xH.† Spurious interrupt at level xH.†
5	** 5** RESET error Status Register not reset. UART not reset.
6	** 6** UART transmit/receive error (A originate) Channel A transmitted data: xxH.† Channel B or A received data: xxH.†
7	** 7** UART transmit/receive error (B originate) Channel B transmitted data: xxH.† Channel A or B received data: xxH.†
8	** 8** UART port error Output port data: xxH.† Input port data: xxH.†
9	** 9** UART interrupt error
10	**10** Replace U5

† x indicates a HEX digit.

At the end of the auto SERIAL test, each type of error that occurred will be displayed along with the number of times it occurred. The error message display will be suppressed after 100 occurrences, but the **number** of occurrences will continue to be updated.

Read the error messages—they are for your guidance.

Troubleshoot the interface PCA starting with the procedure for the error type having the **highest** priority.

11. Potential Problems in Interpreting Error Messages:

- a. If the computer latches up after displaying the last found error type and will not display a summary of all errors received, press (Shift)(CTRL)(Reset). This will allow you to troubleshoot the PCA with given errors. (A summary will **not** be displayed).
- b. If the computer is in an infinite loop, displaying **one** error type for longer than 5 minutes, press (Shift)(CTRL)(Reset) and troubleshoot the PCA for error messages given.

This is the only case for which you abort the auto serial test

- 12. No Error Messages:** If no errors are found during the auto serial test, the following message will be displayed: "The serial card passed." The problem may be intermittent: run the continuous complete test by pressing the (f1) function key in the **1st Serial menu**.

The continuous complete test will run continuously. The number of passes through the test will be displayed in the (f1) **function key area** of the Integral PC display. Any error conditions that are found will be displayed and printed in the same format that is used for the auto serial test.

If several error conditions are found in the first several passes of the continuous complete test, abort the test and go to the section on interpreting error messages. Troubleshoot the interface board under test with the error type(s) found.

If no errors are found while running the continuous complete test, try to configure the system like the customer's system. In doing this, the error condition may be duplicated. If it is not possible to duplicate the customer's system configuration or if no errors are found when the system is duplicated, return the interface to the customer—"no trouble found."

- 13. Troubleshooting Procedures:** Table 8-3 shows error types and the starting page numbers of corresponding troubleshooting procedures. Remember to use the displayed error type having the **highest** priority (1 is the highest priority, 10 is the lowest) to troubleshoot the serial interface PCA.

Table 8-3. Error Types/Troubleshooting Procedures Index

Error Type	Page
1	8-14
2	8-16
3	8-19
4	8-20
5	8-22
6	8-23
7	8-24
8	8-25
9	8-26
10	8-26

14. Troubleshooting Notes:

- If an error condition is **not** found when using the troubleshooting procedure, rerun the auto serial test. If the same error type occurs with no error condition present, replace the PCA and verify that the interface is good. (See section 8.3.4 below).
- If an error condition **is** found, correct the problem and verify that the interface is good. If more than one item can possibly cause a problem, **replace items one at a time. Perform the verification procedure after each item has been replaced.** Note that some ICs may become slightly warm, but none should be hot to the touch.
- Check for hot ICs **before** troubleshooting: **a hot IC is a likely source of trouble.**
- **Always check for opens and shorts before replacing any IC.**

8.3.4 Verification Procedure

Points to remember:

- Assume a good HP Integral PC, RS-232-C serial connector, and 00095-60902 port extender.
If at any time during the tests the computer, connector or port extender appear to malfunction, determine that they are good before proceeding.
- **If any IC fails repeatedly, replace the PCA.**
- **Refer to the General Troubleshooting Flowchart (figure 8-3).**

Procedure:

1. **Rerun the auto serial test.**
2. If no errors are found, the interface PCA has been repaired: return it to the customer.
3. If there are error(s), use the following procedure:
 - a. **If SAME error type, verify that the problem has been corrected by using the appropriate loop test.** If the problem has been corrected and another error condition has been found, continue troubleshooting.

If problem has **not** been corrected, study the schematic diagram for a better understanding of the situation. Continue troubleshooting, or replace the PCA.
 - b. **If different error type, continue troubleshooting.**

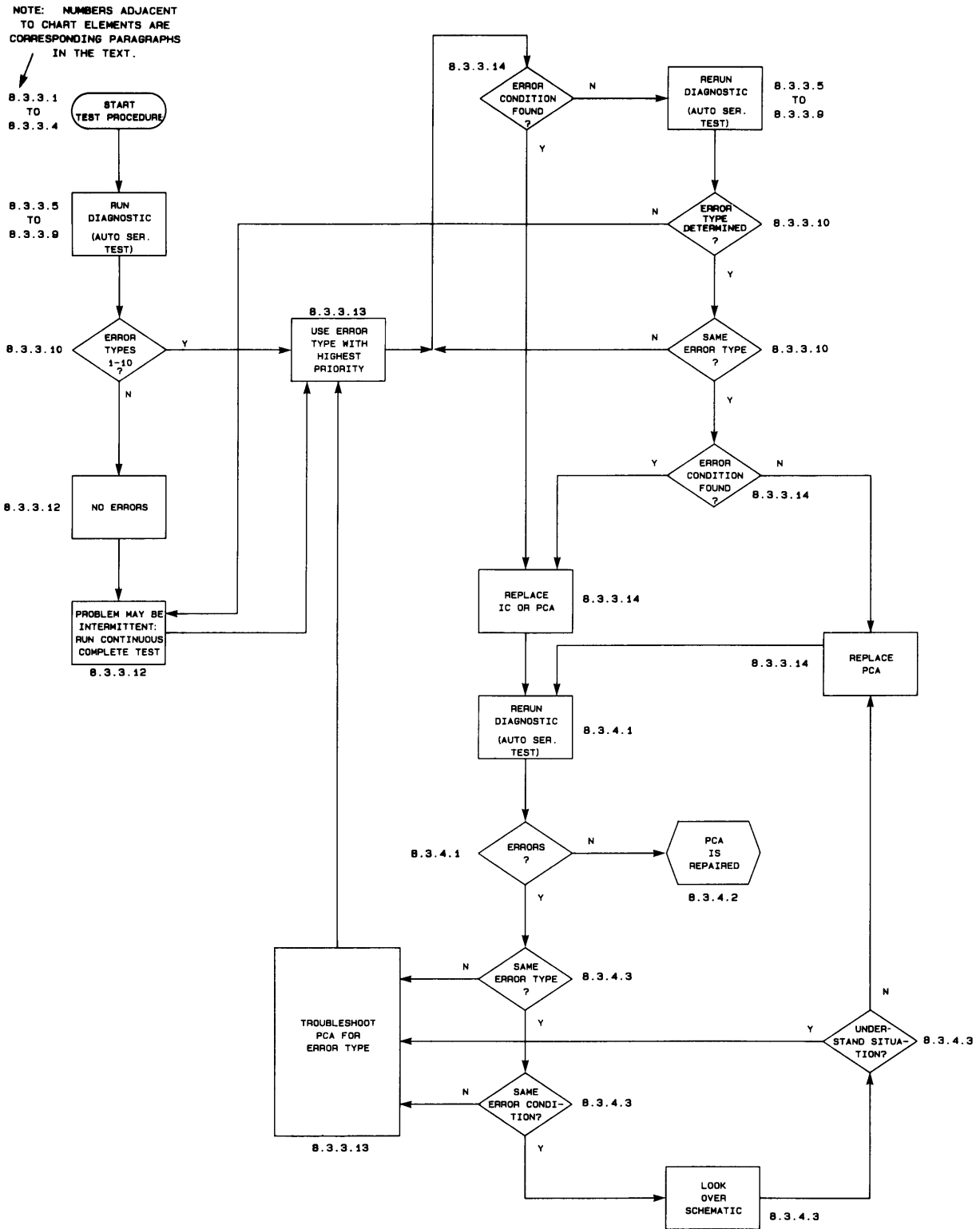

Figure 8-3. General Troubleshooting Flowchart

8.3.5 Description of Tests

Table 8-4 shows the format of the HP Integral PC function keys covering selection of the programmed diagnostic tests.

Table 8-4. Diagnostic Test Select Keys

Screen 1							
F1	F2	F3	F4	F5	F6	F7	F8
Cont. Complete Test	DTACK Test	Data Test	Address Test	ID/Status Register Test	Interrupt Test	UART Interrupt Test	-ETC-†
Screen 2							
F1	F2	F3	F4	F5	F6	F7	F8
UART Port Test	UART Transmit Test	Reset Test	Send to Printer? (Yes/No)				-ETC-†
† The -ETC- function key toggles between the two menus.							

All of the following tests can be aborted by **simultaneously** pressing

Shift **CTRL** **Reset**,

whereupon another test can be selected.

Whenever a **continuous loop test** is aborted, the following message will prompt for another test selection:

Select test with the function key .

When a test selection is keyed in, the following message will always be displayed:

Press **Shift** **CTRL** **Reset** together to exit.

1. **Cont. Complete test.** This routine executes a continuous loop which tests all of the circuitry on the RS-232-C serial interface PCA. When invoked, the following message will be displayed:

CONTINUOUS COMPLETE TEST

The number of passes through this test will be displayed in the (f1) function key area in the HP Integral PC display.

2. **DTACK test.** This routine executes a continuous loop of reading the ID/Status register. When invoked, the following message is displayed:

DTACK TEST

3. **Data test.** This routine executes a continuous loop which walks a '1' across **bus data** lines BD7-BD0 by writing and then reading a UART data register. When invoked, the following message is displayed:

DATA TEST

4. **Address test.** This routine executes a continuous loop which walks a '1' across the **address** lines while a 'read' is being executed. When invoked, the following message will be displayed:

ADDRESS LINE TEST

5. **ID/Status Register test.** This routine verifies that the ID/Status register can be accessed (written to and read from). The routine walks a '1' across the **upper 4 bits** of the ID/Status register. When invoked, the following message will be displayed:

ID/STATUS REGISTER TEST

6. **Interrupt test.** This routine executes a continuous loop which verifies that the RS-232-C serial card can generate interrupts. When invoked, the following message will be displayed:

INTERRUPT TEST

7. **UART Interrupt test.** This routine executes a continuous loop which causes the UART's interrupt request line to toggle from the inactive to the active state. When invoked, the following message will be displayed:

UART INTERRUPT TEST

8. **UART Port test.** This routine executes a continuous loop which walks a '0' across the output pins OP4-OP0 of the UART. **The 82919-60903 Serial Test Connector must be in place to connect the output port to the the input port.** Note that output OP4 is connected to both IP4 and IP5. When invoked, the following message will be displayed:

UART PORT TEST

9. **UART Transmit test.** This routine executes a continuous loop which transmits a pattern of **alternating 0's and 1's (55H)** via the channel A and channel B transmitters. **The 82919-60903 Serial Test Connector must be in place to connect the transmitter to the receiver.** When invoked, the following message will be displayed:

SERIAL TRANSMITTER TEST

10. **Reset test.** This routine causes a **hard** reset which should reset the RS-232-C interface PCA. When this test is invoked, the computer display will be blanked since the computer is also being reset. When the test is completed, the **2nd Serial menu** will be displayed with the following message:

```
RESET TEST
```

Depending upon the result of this test, one of the following messages will appear under the main message:

```
Status Register not reset
```

```
UART not reset
```

```
All IC's passed reset test .
```

Another test can now be selected.

Function key (f4) in the **2nd Serial Menu** provides for the output to be printed. If the printer has paper when the auto serial test is started, the response to "Send to Printer?" is YES. Conversely, if the printer does not have paper, the response is NO. After the auto serial test has run, the key will toggle between the two responses. Remember to press the red "out of paper" indicator button **AFTER** loading paper.

8.3.6 Error Types, Causes, and Repair Procedures

Power-UP Problems. (Main PAM window does not appear in the display).

1. **Description.** The PCA is causing an error condition that prevents the system from initializing.
2. **Probable Cause(s).**
 - An interrupt line is being held **low**.
 - The NBDTACK line is being held **low**.
3. **Troubleshooting Procedure.** If a test signal is NOT correct, replace components *one-at-a-time*:

Verify per section 8.3.4 after EVERY replacement.

Step	Action
a. Check the NBDTACK line (U9-3) for +5V.	Pass—Go to b. Fail—Check U9-2 for +5V ($\approx 3.8V$). Pass—Replace U9. Fail—Check U9-9 for +5V ($\approx 4.9V$). Pass—Replace U9. Fail—Replace U5.
b. Check interrupt lines NBIR3-NBIR0 (U6-4, 5, 6, 7) for +5V.	Pass—Replace the PCA. Fail—Check the status register outputs U2-7, 2 for 0V, and U2-14, 11 for +5V ($\approx 4.1V$). Pass—Replace U6. Fail—Replace U2.

Type 1 Error ** 1 DTACK not received**

1. **Error Description.** The computer did not receive DTACK from the RS-232-C serial interface; therefore, the interface PCA cannot be tested.
2. **Probable Cause(s).**
 - Faulty power supply on the PCA causes the PCA to malfunction.
 - The UART is not receiving a correct waveform from the 3.6864 MHz crystal.
 - The UART is not being chip selected, so it does not respond when addressed.
 - The UART is not producing DTACK correctly, even with the correct control signals.
 - Faulty UART DTACK buffers (to connector P1-A28).
3. **Troubleshooting Procedure.** If a test signal is NOT correct, replace components *one-at-a-time*:

Verify per section 8.3.4 after EVERY replacement.

For applicable waveforms see figure 12.4.1.

Step	Action
a. Check voltages on the PCA: All voltages to be within $\pm 5\%$ regulation.	
1. +5V (P1-C2).	Pass—Go to 2. Fail—Check capacitors C20 and C7 to C17 for shorts. If shorted, replace capacitor(s). If no shorts, replace the PCA.
2. +12V (P1-C1).	Pass—Go to 3. Fail—Check that the in-circuit forward resistance of CR1 is ≈ 260 k Ω . Pass—Check capacitors C1, C3, and C4 for shorts. If shorted, replace the capacitor(s). If no shorts, replace the PCA. Fail—Replace CR1.
3. -12V (P1-A32).	Pass—Go to 4. Fail—Check that the in-circuit forward resistance of CR2 is ≈ 256 k Ω . Pass—Check capacitors C2, C5, and C6 for shorts. If shorted, replace the capacitor(s). If no shorts, replace the PCA. Fail—Replace CR2.

Step	Action
4. Ground (P1-A1).	Pass—Go to b. Fail—Replace the PCA.
b. Check that the voltage at U5-37 (from the 1k Ω pull-up resistor R1) is \approx 4.9V.	Pass—Go to c. Fail—Check for cold solder joint(s) on R1. TURN OFF THE COMPUTER and check that the in-circuit resistance of R1 is \approx 1 k Ω : The ohmmeter MUST have its +ve terminal on pin U5-37 and its -ve terminal on the +5V side of R1. Pass—Unsolder and remove U5, turn the power back on, and check the voltage at pin U5-37. Pass—Install (solder in) a new UART (U5). Fail—Replace the PCA. Fail—Replace R1.
c. Check the 3.6864 MHz crystal input to the UART U5-32, 33.	Pass—Go to d. Fail—Replace U5. Pass—Go to d. Fail—Replace Y1. Pass—Go to d. Fail—Replace the PCA.
d. Run the DTACK test by pressing the “DTACK Test” function key (f2) in the 1st Serial menu. 1. Check the chip select of the UART: U5-35. 2. Check the DTACKN signal from the UART: U5-9. Verify timing relationship to NPS.	Pass—Go to 2. Fail—Replace U5. Pass—Continue tracing DTACKN and replace any failed IC's. Fail—Replace U5.

Type 2 Error ** 2 UART data error**

1. **Error Description.** Incorrect data was read from the UART.
2. **Probable Cause(s).**
 - The RESET line is being held active (**low**).
 - The UART is not receiving correct control signals.
 - The UART is not sending DTACKN correctly.
 - The UART failed.
 - The data bus transceiver failed.
 - Another IC is trying to drive data onto the bus when the UART is being addressed.
 - The UART address line buffers failed.
3. **Troubleshooting Procedure.** If a test signal is NOT correct, replace components *one-at-a-time*:

Verify per section 8.3.4 after EVERY replacement.

For applicable waveforms, see figures 12.4.1 thru 12.4.3.

Step	Action
a. 1 to 3 occurrences of "UART data error" and no "ID/status register error" messages?	Yes—Replace U5. No—Go to b.
b. Check the crystal input to the UART U5-32, 33. (Figure 12.4.1)	Pass—Go to c. Fail—Replace U5. Pass—Go to c if necessary. Fail—Replace Y1. Pass—Go to c if necessary. Fail—Replace the PCA.
c. Check RESET at U9-5 for +5V.	Pass—Go to d. Fail—Replace U9. Pass—Go to d. Fail—Replace the PCA.
d. Check RESET at U9-6 for ≈ 4V.	Pass—Go to e. Fail—Replace U9. Pass—Go to e. Fail—Possibly U5 or U2 is bad: replace U5 and then replace U2 if necessary; or replace the PCA.

Step	Action
e. Run the data test by pressing the "Data Test" function key (f3) in the 1st serial menu .	Note —The UART data error submessages may provide information on stuck bits which are always in error.
1. Check the signal at U8-8 (ID/SEN') for a constant +5V. ($\approx 4.2V$)	Pass—Go to 2. Fail—Run the ID/status register test by pressing the "ID/Status Register Test" function key (f5) in the 1st Serial menu . (Figures 12-4.3.1 and 12-4.3.2)
	Check the signal at U8-8 (ID/SEN'). Pass—Replace the PCA. Fail—Trace the signal and replace any failed ICs.
2. Check chip select of the UART U5-35. (See figure 12-4.1)	Pass—Go to 3. Fail—Replace U5.
3. Check the read/write line to the UART: U5-8. (See figure 12-4.2)	Pass—Go to 4. Fail—Trace the signal and replace any failed ICs.
4. Verify that DTACKN is the correct pulse width: U5-9. (See figure 12-4.1)	Pass—Go to 5. Fail—Replace U5.
5. Check the data bus at U5. If possible start with the data bits that the submessages indicate as bad . (See figure 12-4.2)	Pass—Check the data bus BD7-BD0 at connector P1 (other side of transceiver U1). Pass—Go to f. Fail—Replace U1.
	Fail—Go to 6.
6. If an ID/status register error did not occur and:	
a. read bits are incorrect	Replace U5.
b. write bits are incorrect	Replace U1.

Step	Action
<p>7. If an ID/status register error did occur, several ICs could be the cause.</p> <p>If <i>only</i> bits 3-0 are in error, U4 is the most likely cause (U1 or U5 is the next most likely cause).</p> <p>Unsolder U4 and rerun the UART data test (press key (f3) in the 1st Serial menu). Check data bits at U5.</p> <p>If <i>only</i> bits 7-4 are in error, U2 or U3 is the most likely cause (U1 or U5 is the next most likely cause).</p> <p>Unsolder U3 and rerun the UART data test (key (f3) in the 1st Serial menu). Check data bits at U5.</p> <p>If any data bits between 3-0 <i>and</i> between 7-4 are in error, transceiver U1 or the UART U5 are the most likely causes.</p> <p>Try replacing U1 and then rerun the UART data test (key (f3) in the 1st Serial menu). Recheck all 8 bits of the data bus.</p>	<p>Pass—Replace U4. Fail—Replace U5 or U1, or replace the PCA as best fits the situation.</p> <p>Pass—Replace U3. Fail—Unsolder U2 and rerun the UART data test. Pass—Replace U2. Fail—Replace U5 or U1, or replace the PCA as fits the situation.</p> <p>Pass—Go to f if necessary. Fail—Unsolder U5 and run the ID/status register test by pressing key (f5) in the 1st Serial menu. Check all 8 bits of the data bus. Pass—Replace U5. Fail—Replace U2, U3, or U4, or replace the PCA, as fits the situation.</p>
<p>f. Run the address test by pressing the "Address Test" function key (f4) in the 1st Serial menu.</p> <p>Check the four address lines BA4-BA1 at the inputs and outputs of inverters U4 and U3: they should be making solid 0-to-1 and 1-to-0 transitions.</p>	<p>Pass—Replace U5. Fail—Replace U3 or U4.</p>

Type 3 Error ** 3 ID/Status Register error**

1. **Error Description.** Incorrect data read from the ID/Status register.
2. **Probable cause(s).**
 - Incorrect control signal to the ID/Status register.
 - The ID register failed.
 - The Status register failed.
3. **Troubleshooting Procedure.** If a test signal is NOT correct, replace components *one-at-a-time*:

Verify per section 8.3.4 after EVERY replacement.

For applicable waveforms, see figures 12-4.3.1 and 12-4.3.2.

Step	Action
a. Run the ID/status register test by pressing the "ID/Status Register Test" function key (f5) in the 1st Serial menu . Check the control at U8-8 (ID/SEN'). (Figure 12-4.3.1)	Pass—Go to b. Fail—Trace the signal and replace any failed ICs. (Figure 12-4.3.2)
b. Check the clock signal of the status register U2-9. (Figure 12-4.3.1)	Pass—Go to c. Fail—Trace the signal back and replace any failed ICs one-at-a-time . (Figure 12-4.3.2)
c. If the submessage "ID was read as xH instead of 2H" is displayed (during the auto serial test), check the inputs and outputs of ID register U4. (Figure 12-4.3.1) Inputs: U4-8, 6, 4, 2 and Outputs: U4-18, 16,14,12.	Pass—Go to d if necessary, or replace the PCA. Fail—Replace U4.
d. If one of the three status submessages is displayed:	
1. Check the outputs of the status register: U2-15, 14, 11, 7, 2. (Figure 12-4.3.1)	Pass—Go to 2. Fail—Replace U2.
2. Check the signal at U7-4 for +5V.	Pass—Go to 3. Fail—Replace U5.
3. Check the signal at U7-6. (Figure 12-4.3.1)	Pass—Go to 4. Fail—Replace U7.
4. Check the outputs of the status register buffer: U3-18, 16, 14,12. (Figure 12-4.3.1)	Pass—Continue troubleshooting if necessary. Fail—Replace U3.

Type 4 Error ** 4 Interrupt error**

1. **Error Description.** The interrupt generating logic is not functioning correctly.
2. **Probable cause(s).**
 - The force interrupt bit is not working correctly.
 - The interrupt decoder is not functioning correctly.
 - The interrupt enable bit is not working.
3. **Troubleshooting Procedure.** If a test signal is NOT correct, replace components *one-at-a-time*:

Verify per section 8.3.4 after EVERY replacement.

For applicable waveforms see figures 12-4.3.1, 12-4.3.2 and 12-4.4.

Step	Action
a. Run the ID/status register test by pressing key (f5) in the 1st Serial menu . Check the clock signal of the status register (U2-9). See figure 12-4.3.1.	Pass—Go to b. Fail—Trace the signal and replace any failed ICs one-at-a-time. (Figure 12-4.3.2)
b. Run the interrupt test by pressing the “Interrupt Test” function key (f6) in the 1st Serial menu . (Figure 12-4.4) If the “Missing interrupt at level xH” submessage appears during the auto serial test:	
1. Check the force interrupt bit U2-11.	Pass—Go to 2. Fail — Replace U2.
2. Check U7-4 for +5V.	Pass—Go to 3. Fail—Replace U5.
3. Check U7-6 for correct signal.	Pass—Go to 4. Fail—Replace U7.
4. Ignore any submessage and go to c.1.	

Step	Action
<p>c. If the following submessage appears during the auto serial test: "Configured interrupt level is xH. Incorrect interrupt level at xH." (Figure 12-4.4)</p>	
<p>1. Check the interrupt enable bit U2-14.</p>	<p>Pass—Go to 2. Fail—Replace U2.</p>
<p>2. Check the signals at U6-13, 3, 1.</p>	<p>Pass—Go to 3. Fail—Replace U6.</p>
<p>3. Check the signals at U6-7, 6, 5, 4.</p>	<p>Pass—Replace the PCA. Fail—Replace U6.</p>
<p>d. If the "Spurious interrupt at level xH" submessage appears during the auto serial test: (Figure 12-4.4).</p>	
<p>1. Check the force interrupt bit U2-11.</p>	<p>Pass—Go to 2. Fail — Replace U2.</p>
<p>2. Check U7-4 for +5V.</p>	<p>Pass—Go to 3. Fail—Replace U5.</p>
<p>3. Check U7-6 for correct signal.</p>	<p>Pass—Go to 4. Fail—Replace U7.</p>
<p>4. Check the interrupt enable bit U2-14.</p>	<p>Pass—Replace the PCA. Fail—Replace U2.</p>

Type 5 Error ** 5 RESET error**

1. **Error Description.** The PCA is not receiving RESET, or one (or more) of the ICs is not being reset.
2. **Probable Cause(s).**
 - The RESET buffer has failed.
 - Internally, the UART is not being reset.
 - Internally, the status register is not being reset.
 - The clock to the status register failed.
3. **Troubleshooting procedure.** If a test signal is NOT correct, replace components *one-at-a-time*:

Verify per section 8.3.4 after EVERY replacement.

For applicable waveforms see figures 12-4.3.1 and 12-4.3.2.

Step	Action
a. Place the logic probe on pin U9-5 . Run the reset test by pressing the "Reset Test" function key (f3) in the 2nd Serial menu . The logic probe should quickly blink off then on again when the test is run.	Pass—Go to b. Fail—Replace U9. Pass—Go to b. Fail—Replace the PCA.
b. Place the logic probe on pin U9-6 . Run the reset test by pressing the "Reset Test" function key (f3) in the 2nd Serial menu . The logic probe should quickly blink off then on again when the test is run.	Pass—Go to c. Fail—Replace U9. Pass—Go to c if necessary. Fail—Possibly U5 or U2 is bad: replace U5, then replace U2 if necessary; or replace the PCA.
c. If "Status Register not reset" submessage is displayed during the auto serial test: <ol style="list-style-type: none"> 1. Run the ID/status register test by pressing the "ID/Status Register Test" function key (f5) in the 1st Serial menu. Check the control signal at U8-8 (ID/SEN'). (Figure 12-4.3.1) 2. Run the reset test by pressing the "Reset Test" function key (f3) in the 2nd Serial menu. Check the outputs of U2: U2-15, 10, 7, 2 = 0V, U2-14, 11, 6, 3 = +5V. 	Pass—Go to 2. Fail—Trace the signal and replace any failed ICs. (Figure 12-4.3.2) Pass—Go to d. Fail—Replace U2.
d. If "UART not reset" submessage is displayed during the auto serial test:	Replace U5.
e. If "All ICs passed reset test" submessage is displayed during the auto serial test:	Continue troubleshooting if necessary.

Type 6 Error ** 6 UART transmit/receive error (A originate)**

1. **Error Description.** Data path error between the transmitter (channel A) and the receiver (channel B or channel A).
2. **Probable cause(s).**
 - The line driver or receiver failed.
 - The UART failed.
 - The serial test connector failed.
3. **Troubleshooting Procedure.** If a test signal is NOT correct, replace components *one-at-a-time*:

Verify per section 8.3.4 after EVERY replacement.

For applicable waveforms see figure 12-4.7.

Step	Action
a. Run the UART transmit test by pressing the "UART Transmit Test" function key (f2) in the 2nd Serial menu. Check the signal at U5-30.	Pass—Go to b. Fail—Replace U5. Pass—Continue troubleshooting if necessary. Fail—Can either replace U10 or the PCA.
b. Check the output of line driver U10-3.	Pass—Go to c. Fail—Remove the 82919-60903 Serial Test Connector and repeat the test to recheck the outputs. Pass—Verify that the serial test connector is good. If the connector is good, replace receiver U13. Fail—Replace U10.
c. Check the input to the line receiver U13-13.	Pass—Go to d. Fail—Verify that the serial test connector is good. If the connector is good and the error message persists, replace U13.
d. Check the output of the line receiver U13-11.	Pass—If channel A is both receiver and transmitter, go to error type 7 and continue troubleshooting, else replace U5. Fail—Replace U13.

Type 7 Error ** 7** UART transmit/receive error (B originate)

1. **Error Description.** Data path error between the transmitter (channel B) and the receiver (channel A or channel B).
2. **Probable cause(s).**
 - The line driver or receiver failed.
 - The UART failed.
 - The serial test connector failed.
3. **Troubleshooting Procedure.** If a test signal is NOT correct, replace components *one-at-a-time*:

Verify per section 8.3.4 after EVERY replacement.

For applicable waveforms see figure 12-4.7.

Step	Action
a. Run the UART transmit test by pressing the "UART Transmit Test" function key (f2) in the 2nd Serial menu.	
b. Check the signal at U5-11.	Pass—Go to c. Fail—Replace U5. Pass—Go to c if necessary. Fail—Can either replace U11 or the PCA.
c. Check the output of line driver U11-3.	Pass—Go to d. Fail—Remove the 82919-60903 Serial Test Connector and repeat the test to recheck the outputs. Pass—Verify that the serial test connector is good. If the connector is good, replace line receiver U12. Fail—Replace U11.
d. Check the input to line receiver U12-1.	Pass—Go to e. Fail—Verify that the serial test connector is good. If the connector is good and the error message persists, replace U12.
e. Check the output of the line receiver U12-3.	Pass—If channel B is both receiver and transmitter, go to error type 6 and continue troubleshooting; else replace U5. Fail—Replace U12.

Type 8 Error ** 8 UART port error**

1. **Error Description.** UART input and/or output port path failure.
2. **Probable cause(s).**
 - The line drivers or receivers failed.
 - The UART failed.
 - The 82919-60903 Serial Test Connector failed.
3. **Troubleshooting Procedure.** If a test signal is NOT correct, replace components *one-at-a-time*:

Verify per section 8.3.4 after EVERY replacement.

For applicable waveforms see figure 12-4.6.

Step	Action
a. Run the port test by pressing the "UART Port Test" function key (f1) in the 2nd Serial menu .	
b. Use the submessages for this error type to determine if there are any stuck or bad bits.	
c. Check the output port of the UART (U5-29, 28, 12, 27, 13) starting with any bits which were diagnosed as stuck or bad.	Pass—Go to d. Fail—Replace U5. Pass—Go to d if necessary. Fail—Can either replace U10 and/or U-11 (depending on the bad bits) or replace the PCA.
d. Check the outputs of the line drivers U10-11, 8, 6 and U11-11, 6.	Pass—Go to e. Fail—Remove the serial test connector and repeat the test to recheck the outputs. Pass—Verify that the serial test connector is good. If the connector is good, replace U12 and/or U13 line receivers (depending on the bad bits). Fail—Replace the failed line driver IC(s) U10 and/or U11.
e. Check the inputs to the line receivers U12-13, 10, 4 and U13-10, 4, 1.	Pass—Go to f. Fail—Verify that the serial test connector is good. If the connector is good and the error persists, replace U12 and/or U13 (depending on which bits are bad).
f. Verify the outputs of the line receivers U12-11, 8, 6 and U13-8, 6, 3.	Pass—Replace U5. Fail—Replace the failed IC(s) (U12 and/or U13).

Type 9 Error ** 9 UART interrupt error**

1. **Error Description.** The UART did not produce an interrupt correctly.
2. **Probable cause(s).**
 - The UART logic failed.
 - The **external** UART interrupt logic failed.
 - The clock to the status register failed.
3. **Troubleshooting Procedure.** If a test signal is NOT correct, replace components *one-at-a-time*:

Verify per section 8.3.4 after EVERY replacement.

For applicable waveforms see figures 12-4.3.1, 12-4.3.2 and 12-4.5.

Step	Action
a. Run the ID/status register test by pressing the "ID/Status Register Test" function key (f5) in the 1st Serial menu . Check the control signal at U8-6 (ID/SCLK). (Figure 12-4.3.1)	Pass—Go to b. Fail—Trace the signal and replace any failed ICs. (Figure 12-4.3.2)
b. Run the UART interrupt test by pressing the "UART Interrupt Test" function key (f7) in the 1st Serial menu .	
c. Check the signal at U5-21. (Figure 12-4.5)	Pass—Go to d. Fail—Replace U5.
d. Check the signal at U7-6. (Figure 12-4.5)	Pass—Replace the PCA. Fail—Replace U7.

Type 10 Error **10 Replace U5**

1. **Error Description.** The IC designated by U5 (the UART) should be replaced.
2. **Probable Cause.**
 - The UART failed the local loopback test in the diagnostic.
3. **Troubleshooting Procedure.**

Replace U5 and *verify that the replacement is good* (per section 8.3.4).

Chapter 9

Replaceable Parts

9.1 Introduction

This section lists and illustrates the replaceable parts and assemblies of the HP 82919A Serial Interface.

Table 9-1 lists **assembly** level parts descriptions, HP part numbers, and quantities for the interface. An exploded view of the interface is shown in figure 9-1.

Table 9-2 lists parts descriptions, HP part numbers, reference designators, and quantities for the printed circuit assembly (PCA). The component location diagram and schematic diagram are shown in figures 12-3 and 12-5.

9.2 Ordering Information

Replacement parts and NEW assembly can be ordered from the Hewlett-Packard Corporate Parts Center.

Provide the following information for each part (or assembly) ordered:

- a. Interface model number.
- b. HP part number.
- c. Part (assembly) description.
- d. Complete reference designation (if applicable).

Shipping Information: Each interface or printed circuit assembly (PCA) is shipped in an anti-static bag.

Table 9-1. Replaceable Parts for the HP 82919A Serial Interface

Index Number Figure 9-1	HP Part Number	Description	Quantity
1	82919-60901	NEW assembly, printed circuit	1
2	00095-60940	CASE, bottom	1
3	0380-1696	JACKPOST, 4-40	2
4	82919-60904	PANEL ASSEMBLY, back	1
5	0515-1250	SCREW, TIO M3 5.4 LG	4
6	2190-0677	LOCKWASHER	2

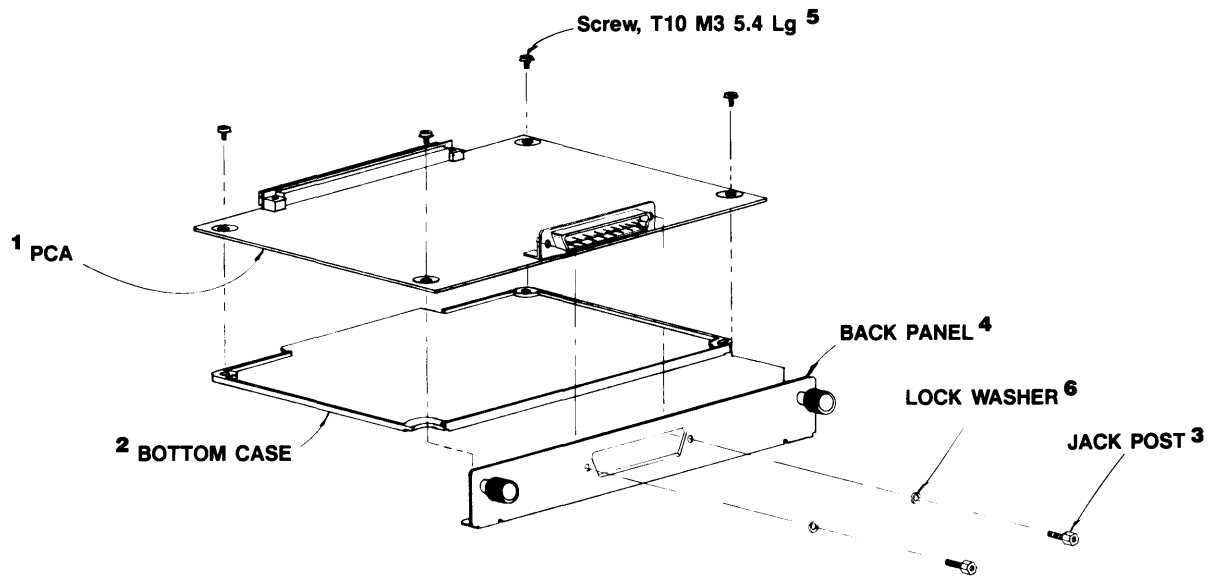

Figure 9-1. Serial Interface Exploded View

Table 9-2. Replaceable Parts for Serial Interface PCA

Reference Designation	HP Part Number	Description	Quantity
C1, C2, C20	0180-3476	CAPACITOR, 22 μ F, 20%, 35V	3
C3-C17	0160-5298	CAPACITOR, 0.01 μ F, 20%	15
C18	0160-4789	CAPACITOR, 15 pF, 5%, 100V	1
C19	0160-4795	CAPACITOR, 4.7 pF, 100V	1
C21-C27	0160-4810	CAPACITOR, 330 pF, 5%, 100V	7
CR1, CR2	1901-1098	DIODE, 1N4150	2
R1	0683-1025	RESISTOR, 1 k Ω , 5%, 1/4W	1
R2, R3	0683-4725	RESISTOR, 4.7 k Ω , 5%, 1/4W	2
U1	1820-3287	INTEGRATED CIRCUIT, transceiver, SN74ALS1245N	1
U2	1820-3466	INTEGRATED CIRCUIT, D-type flip-flop, SN74ALS175N	1
U3	1820-3277	INTEGRATED CIRCUIT, buffer, SN74ALS1244N	1
U4	1820-2951	INTEGRATED CIRCUIT, buffer, SN74ALS240N	1
U5	1820-3667	INTEGRATED CIRCUIT, UART, SCN68681C1N40	1
U6	1820-1427	INTEGRATED CIRCUIT, 2-to-4 decoder, SN74LS156N	1
U7	1820-2656	INTEGRATED CIRCUIT, quad NAND, SN74ALS00N	1
U8	1820-2774	INTEGRATED CIRCUIT, 4-input NAND, SN74ALS20N	1
U9	1820-1568	INTEGRATED CIRCUIT, buffer, SN74LS125AN	1
U10, U11	1820-0509	INTEGRATED CIRCUIT, line driver, MC1488L	2
U12, U13	1820-0990	INTEGRATED CIRCUIT, line receiver, MC1489AL	2
Y1	0410-1523	CRYSTAL, 3.6864 MHz	1

Chapter 10

Reference

Related Equipment Manuals

- 00095-90002 HP Integral PC Owner's manual.
- 82919-90001 HP 82919A Serial Interface Owner's manual.
- 00095-90081 Interface and Memory Module Assembly-Level Service Manual

Applicable Standards Specifications

- Electronic Industries Association (EIA) Standard RS-232-C.
- Comite Consultatif Internationale de Telegraphie et Telephonie (CCITT) Recommendations V.24 and V.28.

Chapter 11

Product History

11.1 Introduction

This chapter tells you about changes in the original computer configuration and how you should adapt the information in this manual to accommodate those changes.

Chapter 12 Diagrams

The following diagrams are referenced at appropriate points in the body of the text.

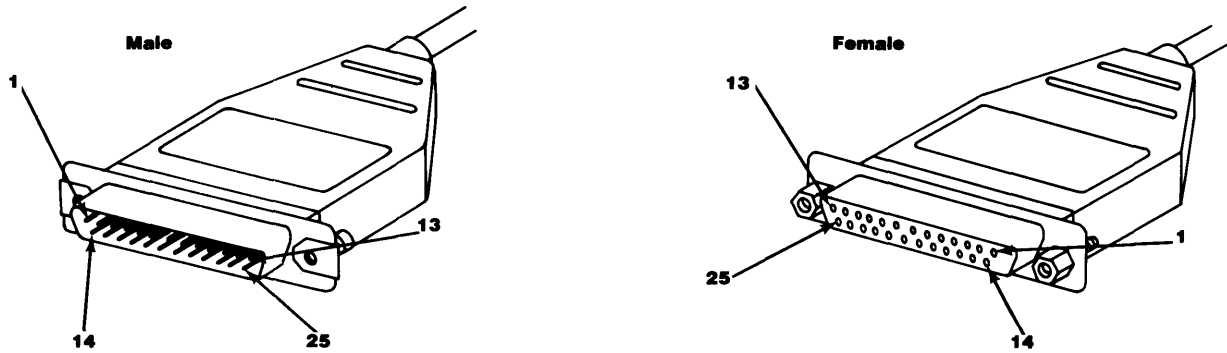

Figure 12-1. RS-232 Connector Pin Numbering

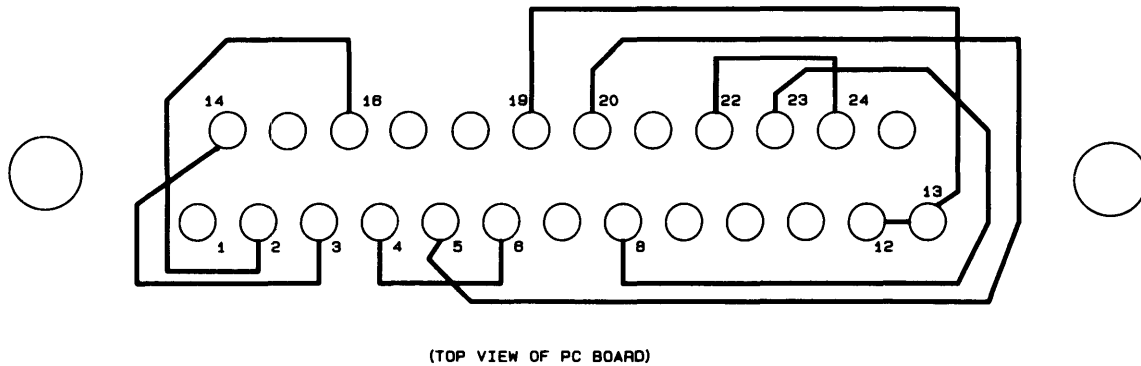

Figure 12-2. HP 82919-60903 Serial Test Connector

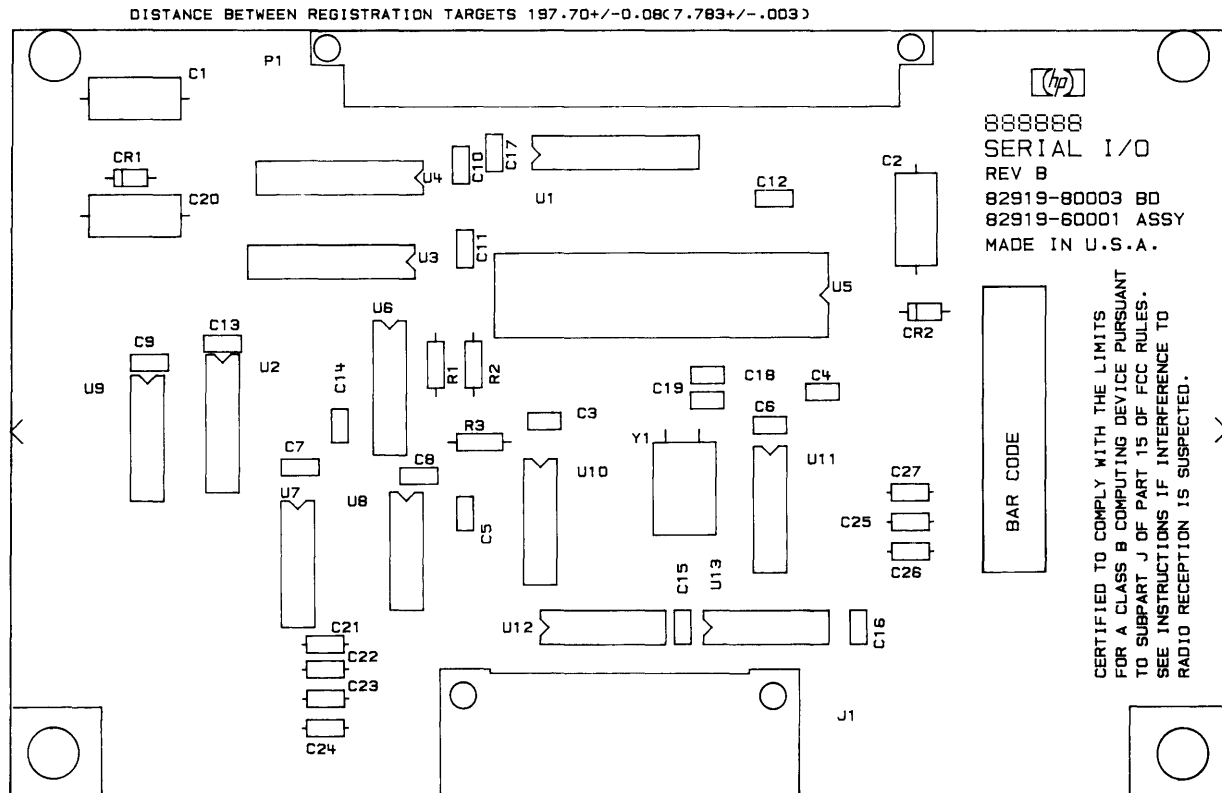
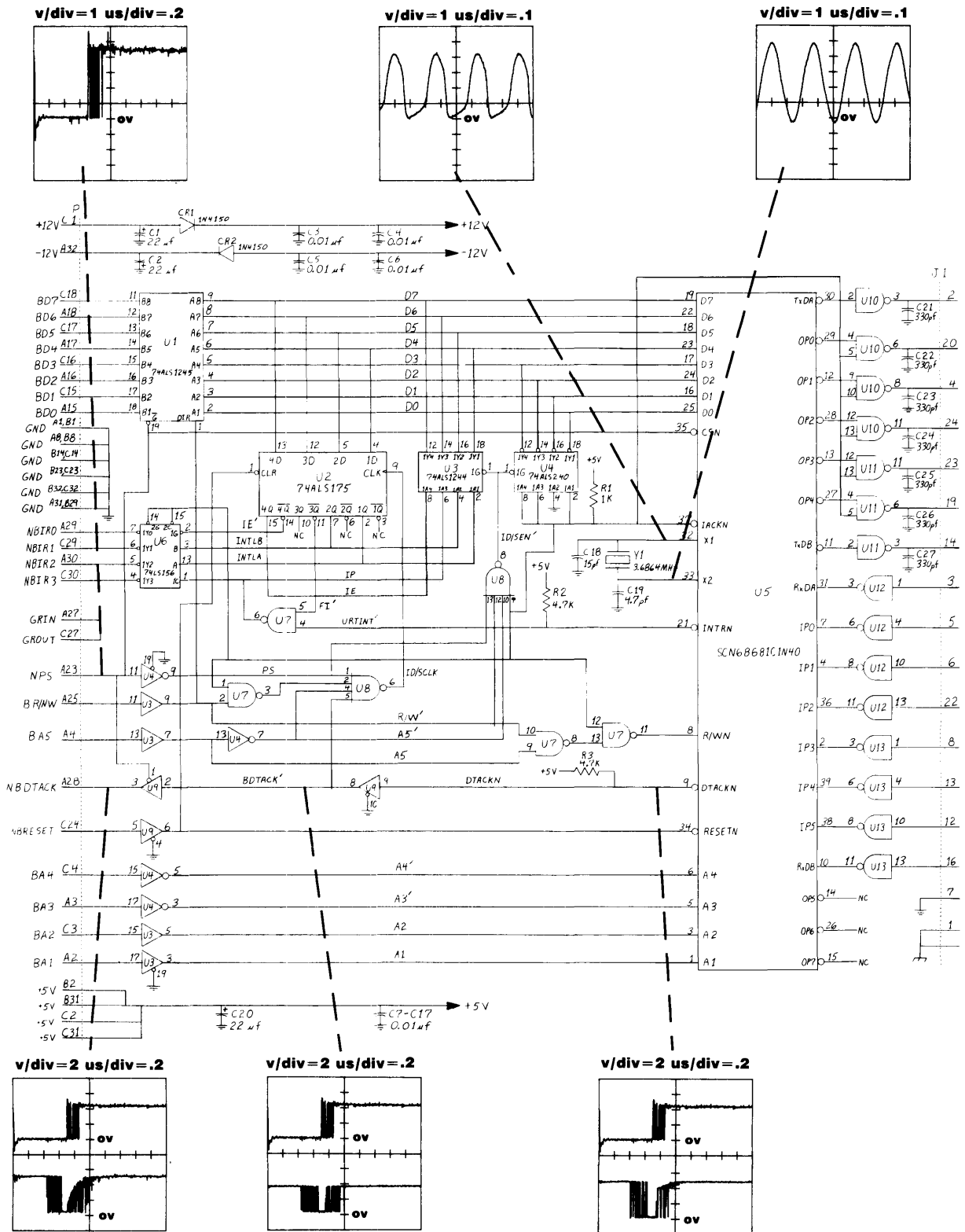
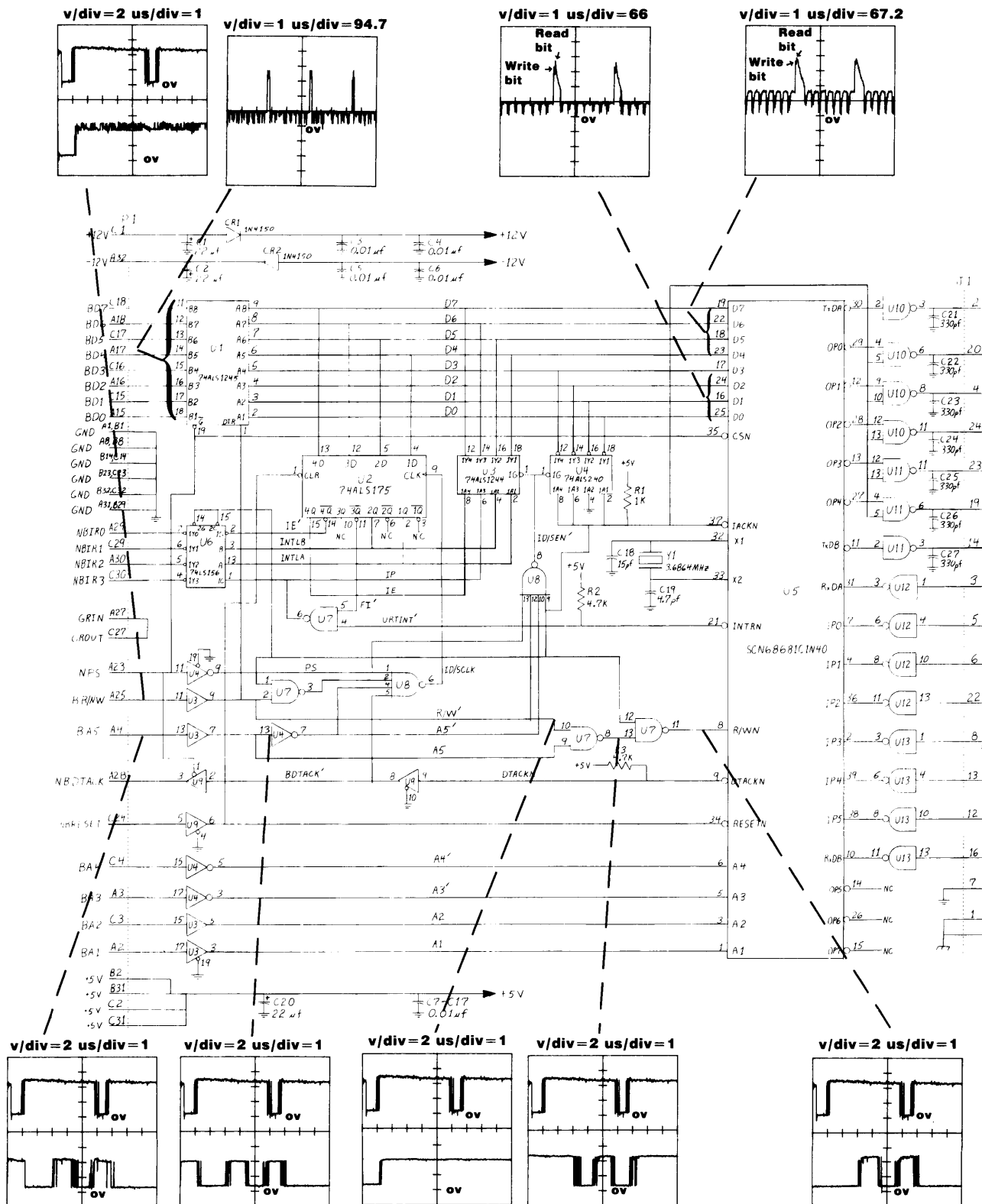

Figure 12-3. PCA Component Location Diagram



Note: When two waveforms appear in a plot the TOP waveform ALWAYS refers to NPS (pin A23).

Figure 12-4.1. General Waveform Schematic



Note: When two waveforms appear in a plot the TOP waveform ALWAYS refers to NPS (pin A23).

Figure 12-4.2. Data Test Waveform Schematic

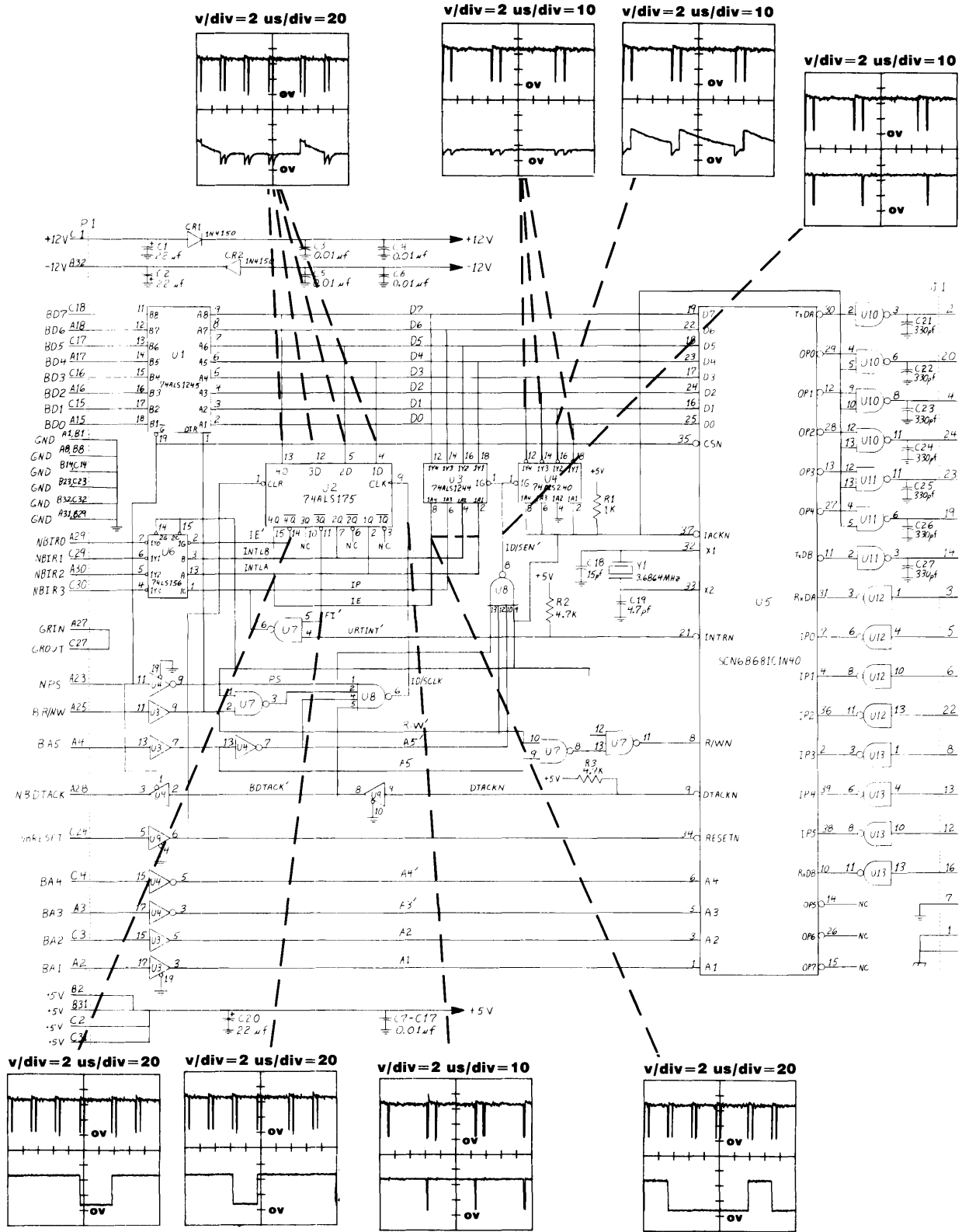

Note: When two waveforms appear in a plot the TOP waveform ALWAYS refers to NPS (pin A23).

Figure 12-4.3.1. ID/Status Register Test Waveform Schematic

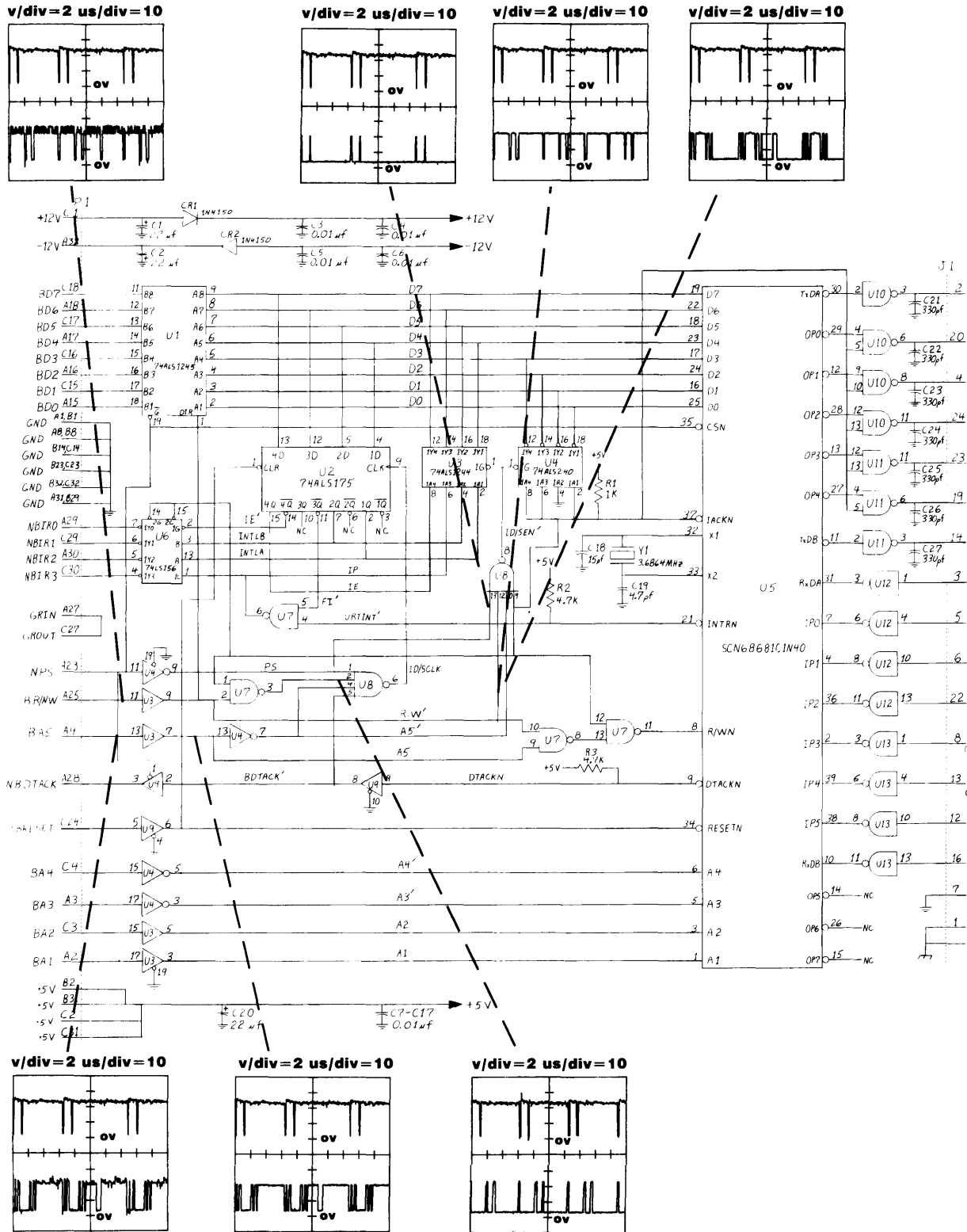

Note: When two waveforms appear in a plot the TOP waveform ALWAYS refers to NPS (pin A23).

Figure 12-4.3.2. I/D Status Register Test Waveform Schematic

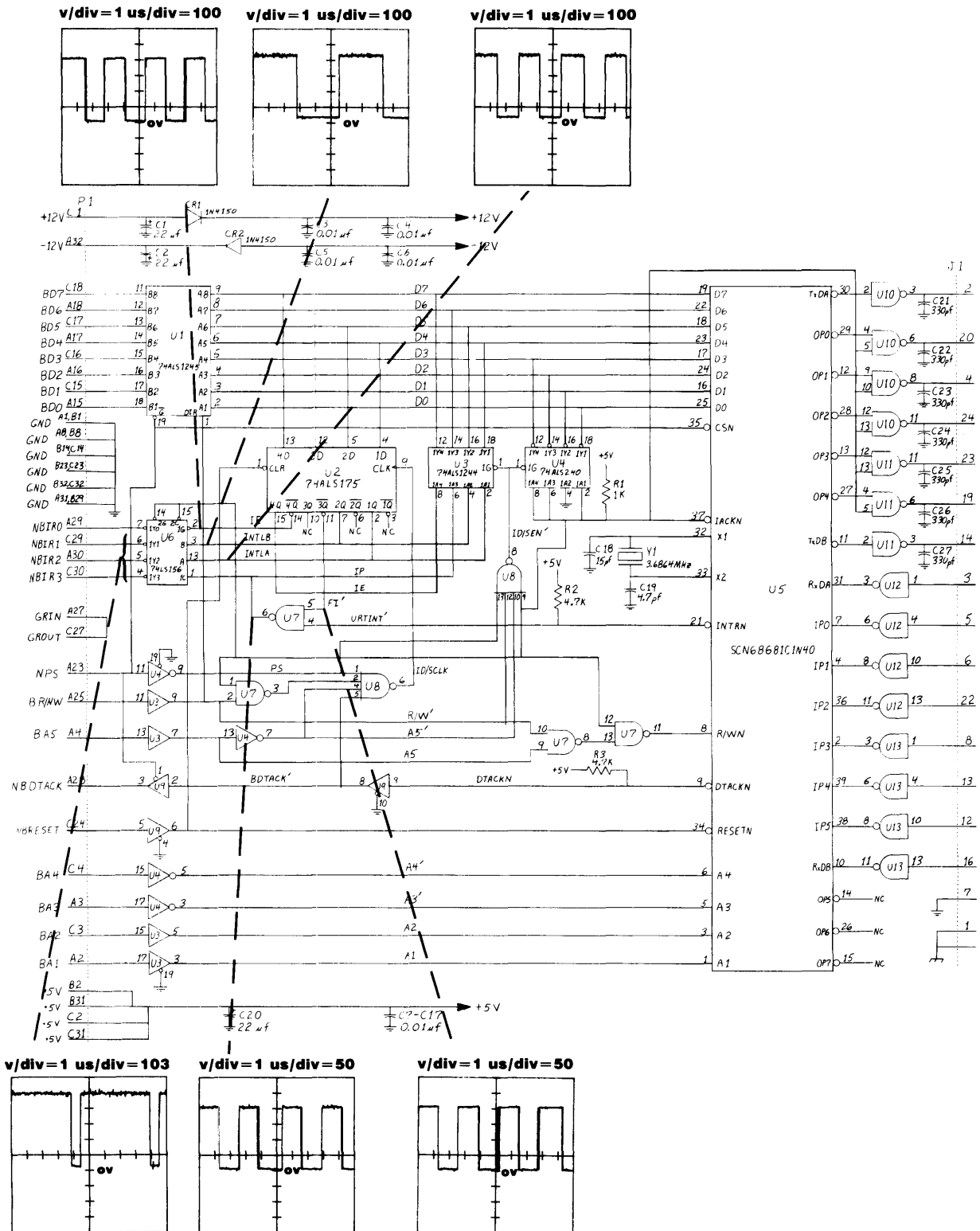
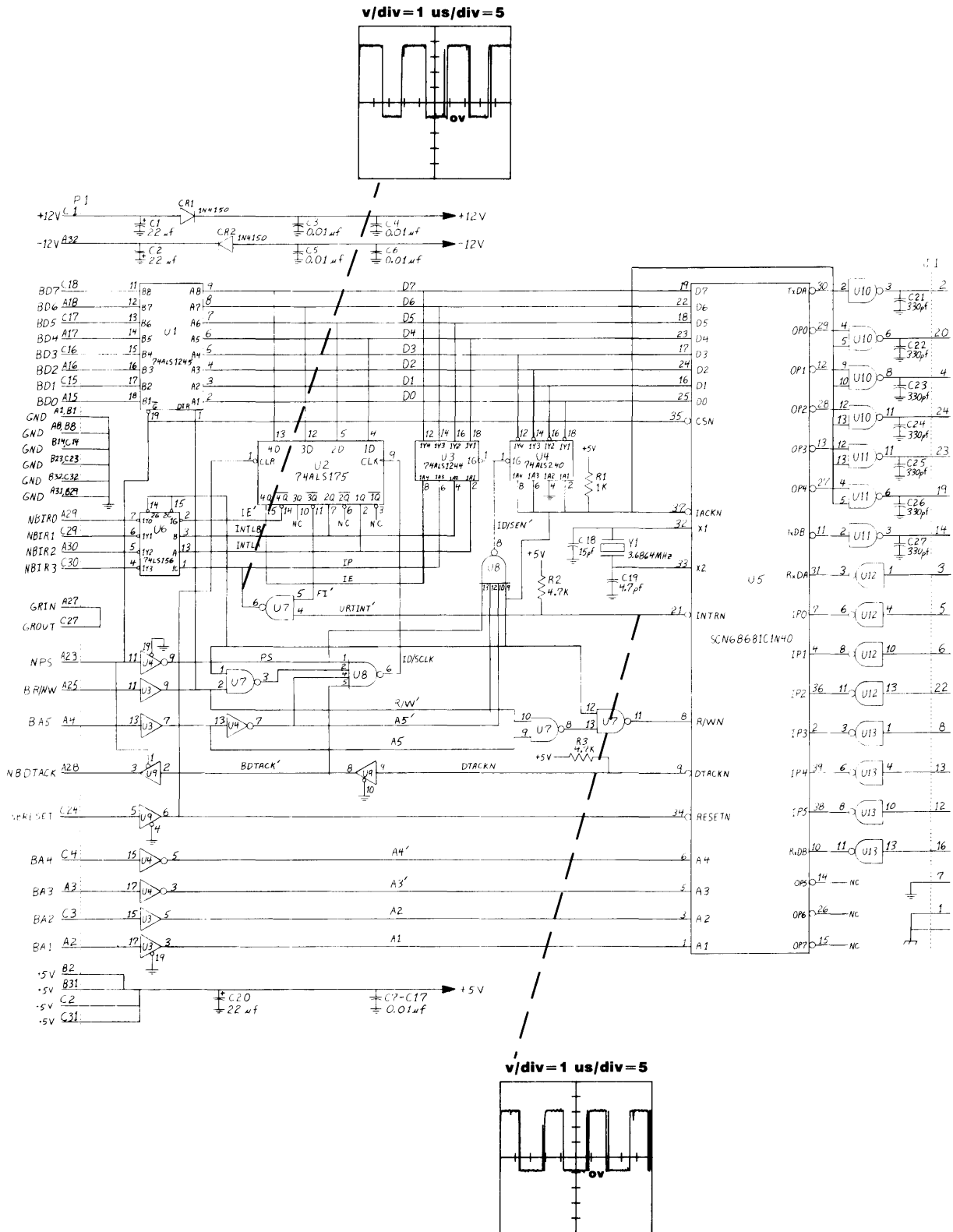
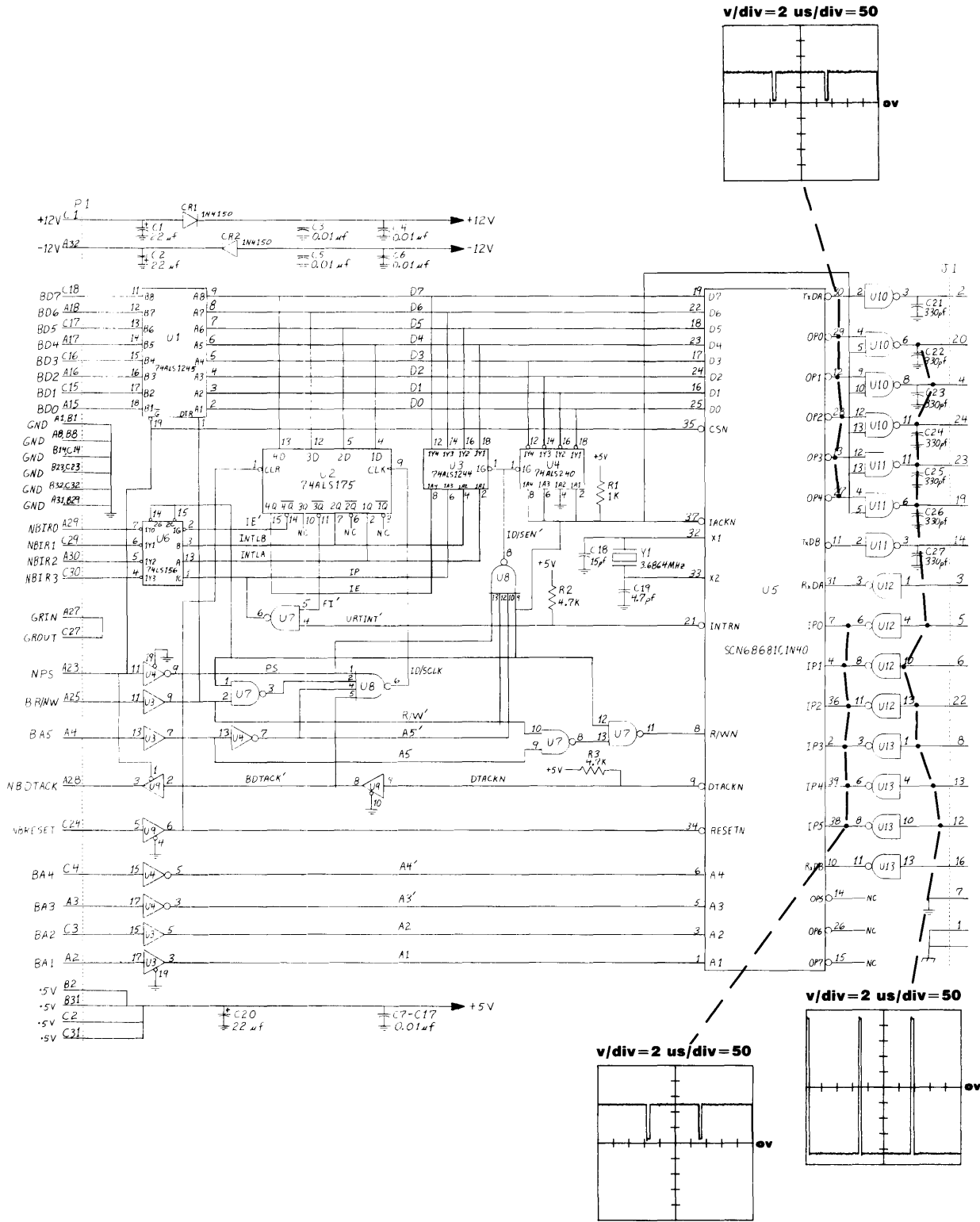

Figure 12-4.4. Interrupt Test Waveform Schematic



Note: When two waveforms appear in a plot the TOP waveform ALWAYS refers to NPS (pin A23).

Figure 12-4.5. UART Interrupt Test Waveform Schematic



Note: When two waveforms appear in a plot the TOP waveform ALWAYS refers to NPS (pin A23).

Figure 12-4.6. UART Port Test Waveform Schematic

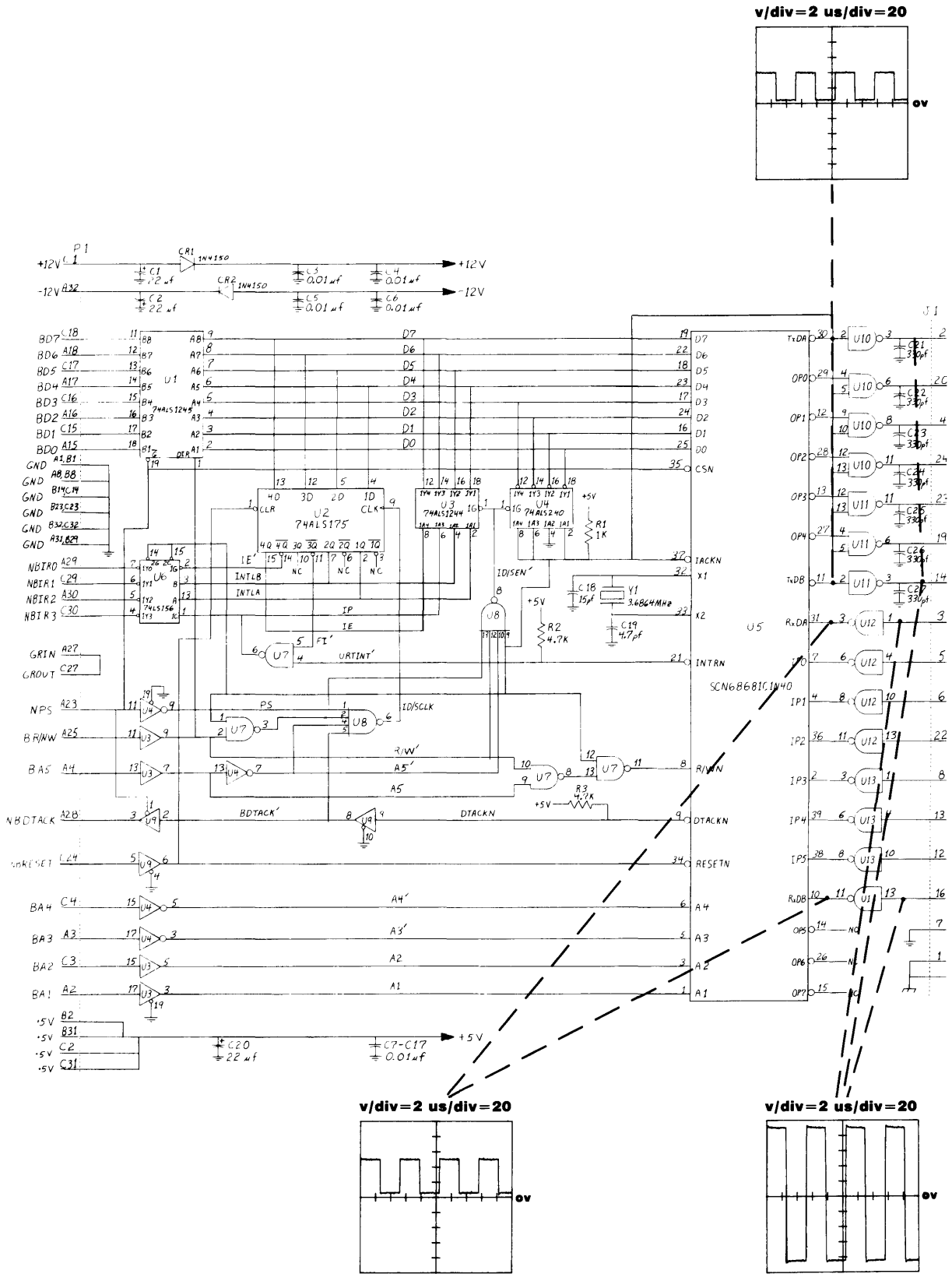

Note: When two waveforms appear in a plot the TOP waveform ALWAYS refers to NPS (pin A23).

Figure 12-4.7. UART Transmit Test Waveform Schematic

Integral PC

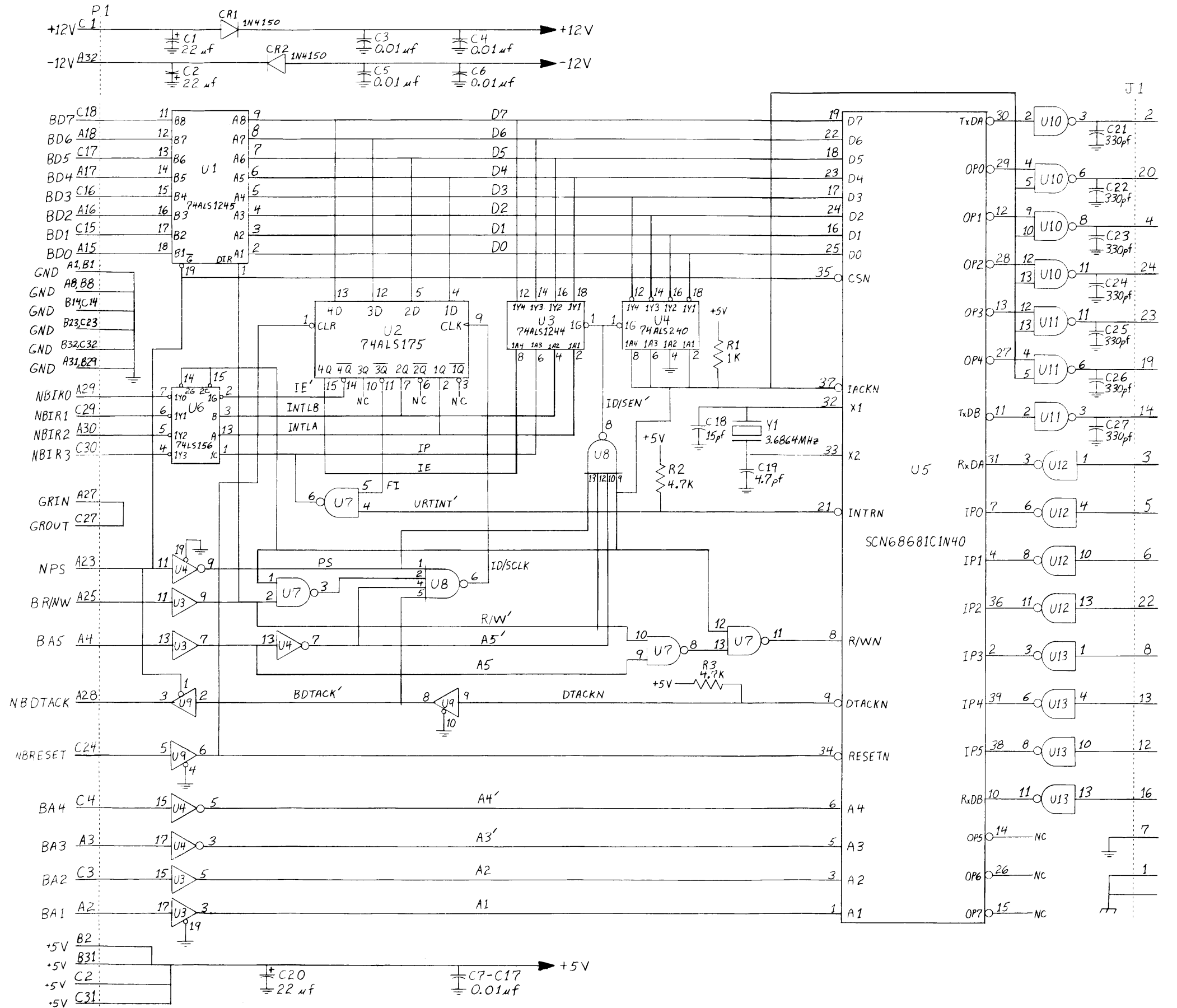



**Portable Computer Division
1000 N.E. Circle Blvd., Corvallis, OR 97330, U.S.A.**

© Hewlett-Packard Company 1984

Reorder Number
82919-90009

Printed in U.S.A. 2/85
82919-90010